

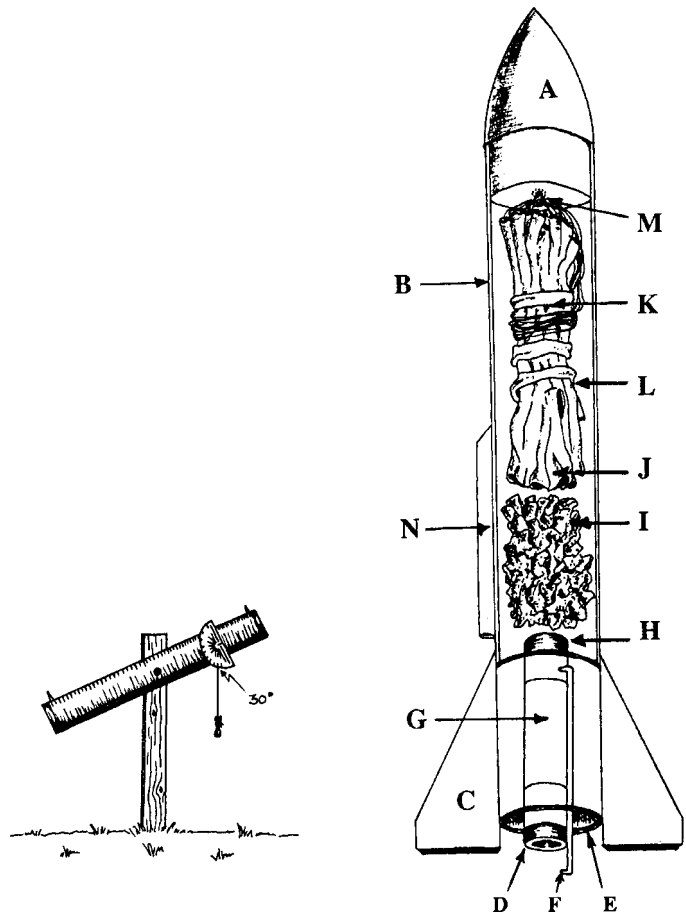

**Agricultural Engineering**  
*Leader's Guide*  
*Unit 1*

# Rocketry



PENNSSTATE



College of Agricultural Sciences  
Cooperative Extension

# This 4-H Rocketry Project *Leader's Guide* belongs to:

|                        |       |
|------------------------|-------|
| <b>Name</b>            | _____ |
| <b>Address</b>         | _____ |
| <b>4-H Club</b>        | _____ |
| <b>School</b>          | _____ |
| <b>County</b>          | _____ |
| <b>4-H Coordinator</b> | _____ |

Prepared by U. B. Bakker, associate professor, Department of Agricultural and Extension Education, in cooperation with members of the Department of Agricultural and Biological Engineering and the 4-H Engineering Science Curriculum Committee.

Visit Penn State's College of Agricultural Sciences on the Web: <http://www.cas.psu.edu>

Penn State College of Agricultural Sciences research, extension, and resident education programs are funded in part by Pennsylvania counties, the Commonwealth of Pennsylvania, and the U.S. Department of Agriculture.

Issued in furtherance of Cooperative Extension Work, Acts of Congress May 8 and June 30, 1914, in cooperation with the U.S. Department of Agriculture and the Pennsylvania Legislature. T. R. Alter, Director of Cooperative Extension, The Pennsylvania State University.

This publication is available in alternative media on request.

The Pennsylvania State University is committed to the policy that all persons shall have equal access to programs, facilities, admission, and employment without regard to personal characteristics not related to ability, performance, or qualifications as determined by University policy or by state or federal authorities. It is the policy of the University to maintain an academic and work environment free of discrimination, including harassment. The Pennsylvania State University prohibits discrimination and harassment against any person because of age, ancestry, color, disability or handicap, national origin, race, religious creed, sex, sexual orientation, or veteran status. Discrimination or harassment against faculty, staff, or students will not be tolerated at The Pennsylvania State University. Direct all inquiries regarding the nondiscrimination policy to the Affirmative Action Director, The Pennsylvania State University, 201 Willard Building, University Park, PA 16802-2801, Tel 814-865-4700/V, 814-863-1150/TTY.

Produced by Information and Communication Technologies in the College of Agricultural Sciences

© The Pennsylvania State University 1994

## Introduction

This leader's guide is to be used in conjunction with the 4-H Model Rocketry Unit I member's guide. The two manuals should be all you need for information. However, much can be learned from **[model]** rocket catalogs.

Prior to the first meeting, send for or obtain from a hobby dealer, a rocket supply catalog. If hobby stores are not handy, model rocket companies are listed in the classified ad sections of magazines such as *Popular Science* and *Popular Mechanics*.

One company manufactures rocket kits that use a **[noncombustible]** liquid fuel and aluminum engines. Many principles in the construction of these rockets differ from those behind the replaceable engine type models for which this project is written. It is advisable not to use the aforementioned rockets for this project even though they are very good products.

*Safety note: This project is designed for club or group activity under the supervision of an adult leader or teacher. Activities involving electricity, rocket fuel, and flying objects require extra safety precautions.*

## Tips for Starting a Rocketry Project Club

1. Consider opportunities to go on rocketry-related field trips. These sites are the best possible classrooms. Encourage club members to coordinate trips to help them develop life skills (interpersonal relationships, leadership, citizenship, etc.)
2. Involve parents in classes, trips, and other activities (**so they also learn**). Involving parents can help club members develop communications skills, leadership, and a sense of values.
3. Don't be afraid to try new things or to use creativity.
4. Offer a variety of projects and activities in an order that will keep 4-H'ers interested, learning, and under control. Encourage them to read directions and to help each other during projects. Ask them to give short talks about their project activities.
5. For some projects, have 4-H'ers bring materials. This will help them learn to assume responsibility.
6. Many new words and terminologies come up while you work on a project. Have a dictionary (or a few) available, so that 4-H'ers can look up that troublesome word.
7. Remember to plan ahead. Some of the suggested projects may need to be set up before the meeting. Involve your 4-H'ers in planning club and project schedules.
8. Safety should be a major concern in all 4-H projects. Do not allow members to run around the work area, as this is a sure way to create accidents. Have a first-aid kit to deal with minor accidents, and plan ahead in case an injury does occur. Treat all injuries, no matter how slight !

9. Be sure to inform your county 4-H agent about your project club. Your agent will be able to tell you about insurance coverage for 4-H clubs, leaders, members, and activities.

10. Read this guide. Following is a list of life skills 4-H'ers can develop by participating in the rocketry project and other 4-H activities. If you need further information and/or training in certain subjects or 4-H leadership areas, please contact your 4-H agent.

## **4-H Life Skills Development**

### **Personal development**

- Develop pride, confidence, and self-esteem
- Understand and use talents and abilities
- Think and make decisions
- Set and meet goals

### **Value development**

- Develop personal work habits
- Develop respect for others
- Become motivated to do quality work

### **Social and interpersonal relationships**

- Work cooperatively with groups or individuals
- Meet new people and make new friends
- Cope with new and changing situations
- Practice sportsmanship and assertiveness
- Accept diversity

### **Leadership**

- Perform officer or committee chairman duties
- Plan and organize group activities
- Teach a skill to others
- Observe and listen
- Identify and solve problems
- Assume responsibility

### **Citizenship**

- Understand one's cultural heritage
- Understand and exercise one's freedoms, rights, and responsibilities
- Understand one's role in family, community, and society
- Plan and implement projects for community benefit

### **Communications**

- Demonstrate skills to a group
- Speak before a group
- Participate in and lead discussions
- Give directions
- Ask questions and make requests
- Listen effectively
- Keep written records

- Express ideas or opinions
- Speak and write persuasively
- Use body language and personal appearance to communicate

### **Career education**

- Plan and prepare for the future
- Determine interests and priorities
- Set and pursue personal goals
- Acquire and budget financial resources

### First Meeting

At the first meeting organize the club and have officers elected. Hold the standard 4-H meeting and when the project time arrives start by handing out the member's guides. (From this point on, the member's guide is set up so you can progress at the rate that best suits the club. [Figure 1] shows a 4-H member constructing a model rocket. [Figure 2] can be used as a guide for constructing the items needed for this project.

## Requirements for 4-H Model Rocketry—Unit I

(see **Member's Guide**, page 1)

1. Option A will give the club a variety of rockets. (Members may choose any single stage model they wish.) Option B will inspire more competition, as various construction and finishing techniques will produce different results on the same model. (Each member will build a single stage model rocket agreed upon by the whole club. In either case be sure they choose a single engine, single stage, rocket kit.)
2. Most kits have a list of different engines recommended for that particular model. Each member must purchase one low-powered engine and one high-powered engine for this project. The members should at this point be looking at catalogs to decide what kits they want. At the next meeting be sure to collect the money and order as a group. Order rockets and engines at the same time.
- 3-7. This becomes self-explanatory as the project progresses.
8. Members must have at least one photo of their rocket or their rocket and themselves to be placed on page 20 of the member's guide. If a club member has a knack for photography, this person might take pictures for each member.
- 9-10. Self-explanatory.

## Project Score

Items (3) and (4) will normally be judged at roundup by the judging team.

## Safety Code

The rules in this code should be easily understood. Members will understand the rules more as the project goes on. They should read and discuss the rules.

When discussing rules (1), (2), and (4), you may refer to the construction of the launch panel, (5) to recovery methods, and #6 to launch pad construction.

## Necessary Equipment

Members may wish to construct all three devices for their own use, launch pad, launch panel, and tracking scope, *but the club needs only one of each*. Members can be divided into three groups, each group being responsible for constructing one of the devices, or the leader may choose another method for obtaining them.

All of these items are for sale from the leading model rocket manufacturing companies, but many clubs will prefer to build their own.

The construction plans given in this manual are very simple yet contain all necessary safety precautions. Each device can be built with more features than shown, as you will see in units to follow.

The wood base for the launch pad can be obtained from a lumber yard or from a home supply. The launch rod can be purchased from a hobby store or a hardware store. Parts for the safety flag can be easily obtained. For the launch control panel, large and small battery clips, doorbell button, and key switches are available from an electrical supply store, along with the wire. Some auto ignition switches are ideal and might be gotten from a junked car.

The box to hold the launch control switches can be constructed by members from scrap wood. Tracking scope materials can mostly be found around the house, items such as the broom handle, small pine board for the sighting stick, some string, and a nut or fishing sinker for weight. The bolt and wing nut should be about 1/8 inch in diameter and about 2 inches long. It can be obtained from a hardware store along with eye screws and brads. The protractor might be found in an old pencil box kit or bought at a dime store.

## Building Your Rocket

Many tips and ideas will be suggested in the rocket catalog that you order from. The kit will include instructions for building the model. You will probably have to read over the instructions carefully so

that you are able to help members with any problems. The tools needed for constructing model rockets are a razor blade or knife, glue, sandpaper, and a pair of scissors.

In this unit, rocket stability, balance, center of gravity, and center of pressure are not discussed. Since you will be working with kits that have been constructed many times, there should be no stability problems if the instructions are followed.

### **Launching Your Rocket**

As leader of this project you are also the Launch Safety Officer. You will watch the loading of the rocket engines, packing of the chutes, and installing of the igniter wires, and you will be responsible for all-around safety of the project. You will be in charge of the launch key and will only turn it over to the launch commander at the proper time and then recover it after the rocket is launched each time.

### **The Rocket Engine**

How the engine works and propels the rocket into the air can be explained by the rule “for every action there is an equal reaction in the opposite direction.” Therefore, as the propellant charge burns and pushes the gas out the bottom (the action), the reaction will be to push the rocket in the opposite direction (up). The different parts of the rocket engine illustrated [in Figure 6] can be named and colored.

### **The Model Rocket**

Emphasize that the rocket illustrated might contain more or fewer parts than the model members chose to build. There are two engine mounting methods listed. Only one of these will be used on a rocket. Emphasize using enough fireproof wadding, because not using enough could cause the plastic chute to melt together by the ejection charge gases. Different parts can be named and colored in.

### **Recovery Systems**

Point out that there is a fourth type of recovery method called *featherweight*. This method is used for rockets that are extremely light and small. If featherweight is given as an answer to one of the questions in the quiz, you will then have to count it correct.

### **Launch Personnel and Their Duties**

The titles and their duties are self-explanatory. Your task as Range Safety Officer and leader will be to see that the titles rotate so everyone gets a chance at every position on the field. It would be advisable to have a first aid kit some place near the Launch Control Center.

### **The Launch Range**

For large engines the launch range should be at least a quarter mile lengthwise. Many fields will not be square or rectangular. As illustrated, use whatever is available to the best advantage. Avoid fields

with high grass or weeds, as finding the rocket after it comes down could be difficult. Also, hidden rocks and branches might cause injuries.

### **Launch Day**

The launch day section gives the typical procedure to follow on launch days. This will be a thrilling experience for members. Watch for safety. You will be initialing the launch record sheets and making sure everything is being done correctly. If there is extra time and it can be managed, you might want to be the timekeeper for the flight duration part of the launch record sheet. This will take some of the burden off the launch recorder. Younger members may have difficulty in multiplication. If so, with your help, the correct answers can be achieved.

### **Rocketry Quiz**

Read the questions. The members will fill in the spaces on their answer sheet.

### **Rocketry Report**

A report is to be written by each member and will be judged at roundup. Emphasize neatness.

### **Angles and Tangents**

The angles and tangents chart is used to help figure the altitude a rocket reaches. The chart is simple to use. When the tracking team reports in an angle, say 41 degrees, go to the chart. Under angle, find 41, which is degrees, and slide right across to the tangent column. You find the tangent is .87. This number is multiplied by the baseline distance used at that particular launch. (See example given in member's guide.)



## 4-H Model Rocketry Quiz and Answers, Unit I

Identify the parts labeled as 1-5. For question 6, tell what the circled number 3 means.

*(Answers)*

1. *Ceramic nozzle*
2. *Propellant charge*
3. *Delay charge*
4. *Ejection charge*
5. *Retaining cap (paper)*
6. *Delay time in seconds*

**Answer the following questions:**

7. Name any two popular recovery systems. (*Parachute, streamer, or tumble recovery system*)
8. What does the fireproof wadding protect? (*Recovery system*)
9. What keeps model rockets out of the fireworks classification? [**sugg. change: what distinguishes model rockets from fireworks?**] (*Being ignited electrically and not by fuse*)
10. What powers your model rocket? (*Premanufactured model rocket engines*)
11. What are nose cones most often made of ? (*Balsa wood*)
12. What is the maximum propellant weight allowed? (*4 oz.*)
13. The launch rod should be at least \_\_\_\_\_ long. When not in use, it should have a \_\_\_\_\_ on it. (*3 feet; safety flag*)
14. Circle the engine with the highest average thrust. (***B 14-5***)
15. In the space provided and with the use of your tangent chart, figure the altitude of this rocket: Tracking station reports an angle of 67 degrees. The baseline is 450 feet. (***Tangent is 2.36; the final altitude is 1,062 feet***)

**True or false?**

16. Homemade fuels are best. (***F***)
17. The weight limit for model rockets is 16 pounds. (***F***)
18. Rocket engines made from metal are recommended. (***F***)

19. Federal regulations govern model rocketry. (*T*)
20. Model rockets fly in the same direction the wind is blowing. (*F*)
21. The main purpose of the key switch is to add “good looks” to the launch panel. (*F*)
22. The launch rod is used to guide rockets during lift-off. (*T*)
23. Fuses are a sure and safe means of igniting rockets. (*F*)
24. The angle on the tracking scope is multiplied by the baseline distance, in feet, to give you the altitude, in feet. (*F*)
25. Because of the way fins are designed, rockets are best launched vertically. (*T*)



**Agricultural Engineering**

*Member's Guide*

*Unit 1*

18 U.S.C. 707

R  
O  
C  
K  
E  
T  
R  
Y

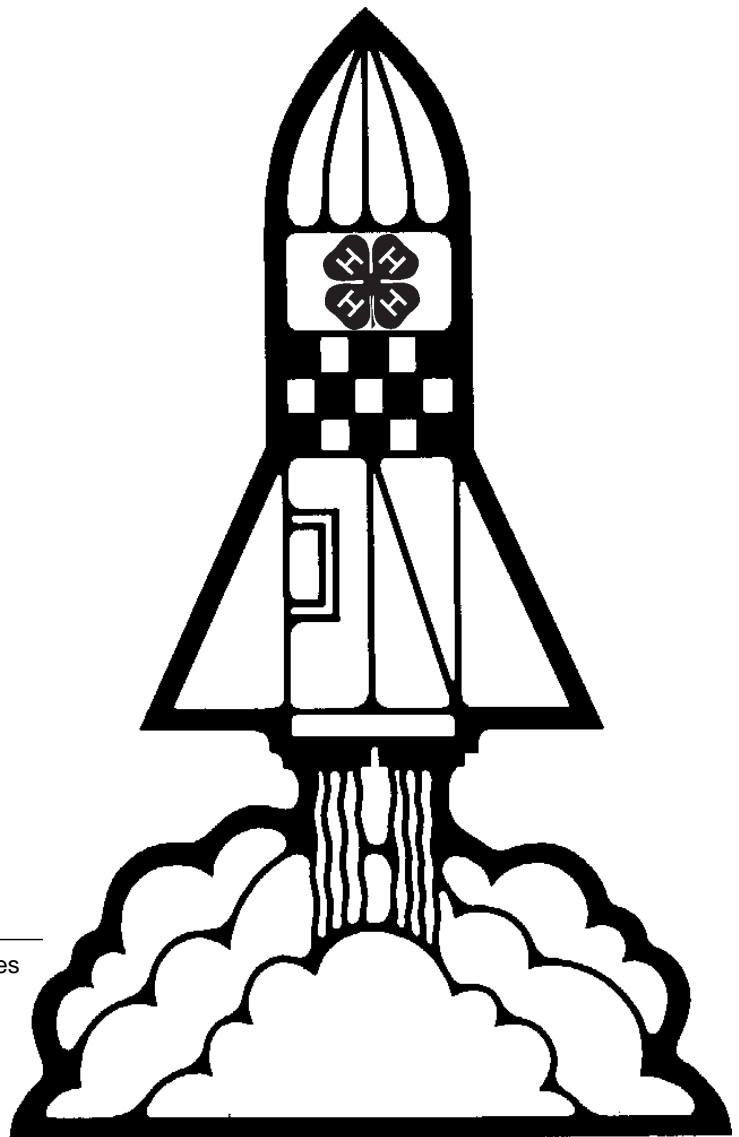
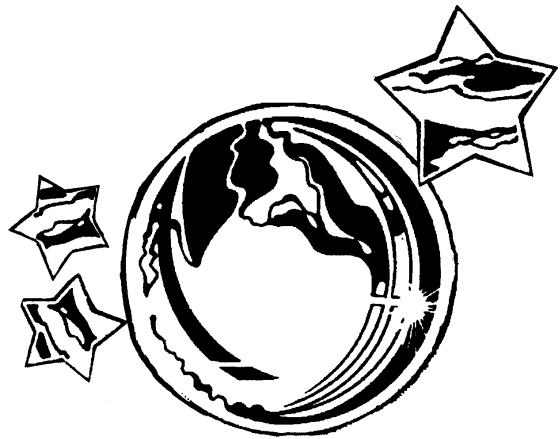

PENNS<sup>T</sup>ATE



College of Agricultural Sciences  
Cooperative Extension

# This 4-H Rocketry Project *Member's Guide* belongs to:

|                        |       |
|------------------------|-------|
| <b>Name</b>            | _____ |
| <b>Address</b>         | _____ |
| <b>4-H Club</b>        | _____ |
| <b>School</b>          | _____ |
| <b>County</b>          | _____ |
| <b>4-H Coordinator</b> | _____ |

Prepared by U. B. Bakker, associate professor, Department of Agricultural and Extension Education, in cooperation with members of the Department of Agricultural and Biological Engineering and the 4-H Engineering Science Curriculum Committee.

Visit Penn State's College of Agricultural Sciences on the Web: <http://www.cas.psu.edu>

Penn State College of Agricultural Sciences research, extension, and resident education programs are funded in part by Pennsylvania counties, the Commonwealth of Pennsylvania, and the U.S. Department of Agriculture.

This publication is available from the Publications Distribution Center, The Pennsylvania State University, 112 Agricultural Administration Building, University Park, PA 16802. For information telephone (814) 865-6713.

Issued in furtherance of Cooperative Extension Work, Acts of Congress May 8 and June 30, 1914, in cooperation with the U.S. Department of Agriculture and the Pennsylvania Legislature. T. R. Alter, Director of Cooperative Extension, The Pennsylvania State University.

This publication is available in alternative media on request.

The Pennsylvania State University is committed to the policy that all persons shall have equal access to programs, facilities, admission, and employment without regard to personal characteristics not related to ability, performance, or qualifications as determined by University policy or by state or federal authorities. It is the policy of the University to maintain an academic and work environment free of discrimination, including harassment. The Pennsylvania State University prohibits discrimination and harassment against any person because of age, ancestry, color, disability or handicap, national origin, race, religious creed, sex, sexual orientation, or veteran status. Discrimination or harassment against faculty, staff, or students will not be tolerated at The Pennsylvania State University. Direct all inquiries regarding the nondiscrimination policy to the Affirmative Action Director, The Pennsylvania State University, 201 Willard Building, University Park, PA 16802-2801, Tel 814-865-4700/V, 814-863-1150/TTY.

Produced by Information and Communication Technologies in the College of Agricultural Sciences

© The Pennsylvania State University 1994

**C0711A** R2M10/01ps4015

## Requirements for 4-H Rocketry Project Unit 1

Initial

1. Build from a kit one single-stage rocket (two options):
  - a. Each club member may choose to build any single-stage model.
  - b. Each member will build a single stage model rocket agreed upon by the whole club.

\_\_\_\_\_
2. Launch your completed rocket at least twice, once with a low power engine and once with a high power engine. \_\_\_\_\_
3. Know and follow the 4-H Model Rocketry Safety Code. \_\_\_\_\_
4. Know how to find altitude with one tracking station. \_\_\_\_\_
5. Know firing circuit operation and firing procedures. \_\_\_\_\_
6. Know rocket parts and engine structure. \_\_\_\_\_
7. Complete the quiz to be given by your leader. \_\_\_\_\_
8. Take a photograph of your rocket for inside back cover of this project book. \_\_\_\_\_
9. Complete all other parts of this book. \_\_\_\_\_
10. Exhibit your rocket and completed project book at roundup. \_\_\_\_\_

### PROJECT SCORE

| <u>Category</u>      | <u>Points Possible</u> | <u>Score</u> |
|----------------------|------------------------|--------------|
| I. Quiz score        | 25                     | _____        |
| II. Book neatness    | 25                     | _____        |
| III. Rocketry report | 25                     | _____        |
| IV. Roundup exhibit  | <u>25</u>              | _____        |

TOTAL 100

AWARD \_\_\_\_\_

Items I and II can be judged prior to Roundup by the 4-H leader or other persons so appointed.

## 4-H Model Rocketry Safety Code

Before you begin the project, read and understand the rocketry safety code. Following this code means success for model rocketry.

1. I will construct my model rockets, making sure there are no substantial metal parts in the vicinity of the rocket's engine. I will not use metallic rocket engines.
2. In my model rockets, I will use only commercially manufactured model rocket engines. I will not tamper with or reload these engines.
3. My model rockets will be ignited *only by electrical means* and at a distance of 20 feet from the launch panel and spectators. My launch panel will contain at least one safety switch to prevent accidental launching.
4. I will not build model rockets that weigh more than one pound (16 ounces) when loaded; and the total propellant will not weigh more than 4 ounces, as governed by federal regulations.
5. My model rockets will employ a recovery system to slow their descent and allow a safe return to earth. Before each launch, I will carefully inspect the recovery system to insure its safe deployment.
6. I will always launch my model rockets from a launching rod, rail, or other suitable guide of at least 3 feet in length and aimed no more than 30 degrees from the vertical.
7. I will check the stability of my model rocket before its first flight. I will launch my rockets only with adult supervision.
8. I will not launch model rockets in high winds, conditions of low visibility, populated areas, areas where they might endanger aircraft in flight, areas where they might present a fire hazard, or under any conditions that might endanger property or persons.
9. My model rockets will not be launched as weapons against targets in the air or on the ground, nor will they contain explosive or pyrotechnic warheads.
10. I will always act in a mature manner with safety first.

## Equipment Needed to Fire and Track the Rocket

Three devices are needed to fire and track the rockets you launch. They are a launch pad/safety flag ; a control panel; and a tracking scope (Figures 1, 2, and 3). These items are for sale from leading model rocket manufacturing companies, but you may prefer to build your own.

The construction plans given in this guide are very simple, yet they contain all necessary safety precautions. Each device can be built with more features than shown.

### 1. Launch Pad

The first item to construct is the launch pad/safety flag. You will need the following materials:

- One launch rod at least 36 inches long and 1/8 inch in diameter. This can be bought at a hobby or hardware store.
- One piece of 1-inch plywood about 1 foot square to make the base.
- A piece of heavy-duty aluminum foil about 3 feet long.

Drill a 1/8-inch hole in the center of the plywood base. Cover the base with the aluminum foil. The top portion should have two layers of foil. To assemble, place the rod into the base and force it down. The foil protects the base from the engine's blast.

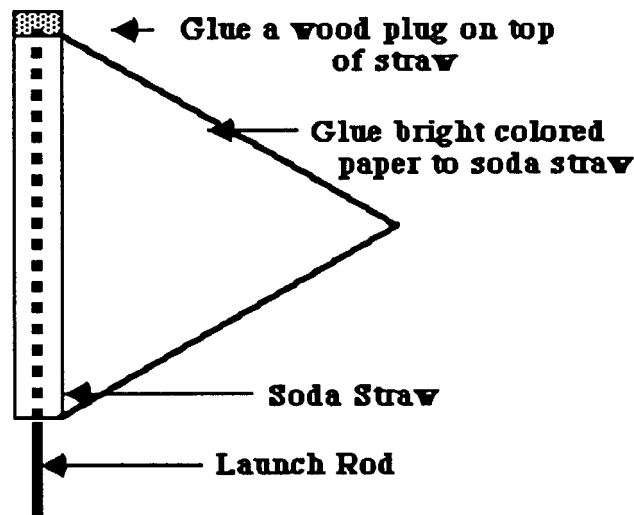

Figure 1. Launch Pad Safety Flag

Build this safety flag with a soda straw, a 1/2-inch piece of wooden rod that fits in the straw, a piece of brightly colored paper, cloth, or plastic, and some glue. The flag can be placed on top of the launch rod. It will alert everyone to the sharp rod and will prevent accidents.

## 2. Control Panel

The launch control panel is shown in Figure 2. Build or obtain a box the size of a large cigar box or larger. It can be made of metal, wood, or strong plastic. Working with wood may be the most satisfactory.

The box will house two switches, one a doorbell button and the other a type requiring a key to open and close the circuit. The switches can be purchased at an electrical or hardware store. (A car ignition switch, with key, can be used for the safety switch. You may be able to get one at a used car parts place.)

Divide a 35-foot length of No. 16 double strand heavy duty extension cord into a 10-foot piece and a 25-foot length. Attach battery clips to the two wires at one end of the 10-foot section. This will be the lead from the battery to the launch control panel. The 25-foot piece of lamp cord will be the lead from the launch control panel to the launch pad. Fasten miniature alligator clips to the two wires on one end of this section of lamp cord.

Drill two holes in the top of the box. The size of the holes will depend on the size of the two switches to be mounted. Drill a second set of holes large enough to allow the extension cords to pass through on the side of the box.

Mount the key (safety) switch and push button (firing) switch. If the box is not open on the bottom, insert the wires through the side holes (before mounting the switches) and through the top holes and fasten the wires as shown on the drawing below. Before fastening the wires, tie a knot about 10 inches from the free end of both the 10-foot and the 25-foot pieces or use wire clamps to keep the cords from being pulled out. Fasten one wire of each section to one of the doorbell button terminals and the other to the safety switch terminals. Fasten the switches securely to the box top. If the box is open on the bottom, you may fasten the switches to the box top first and then follow the same procedure of attaching the wires to the terminals.

The diagram below shows the wiring procedure.

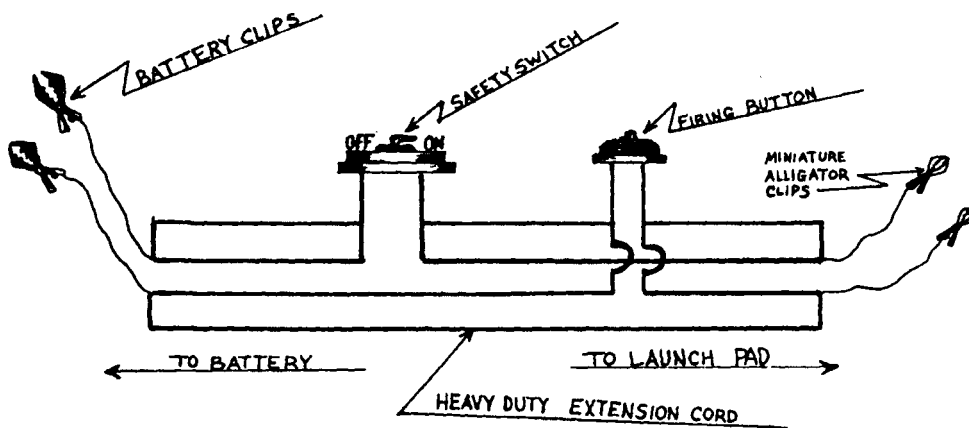

Figure 2. Schematic Drawing of Wiring for Launch Panel



### 3. Tracking Scope

The last item you need to construct is used to determine the height your rocket ascends. You will need the following materials: a broom handle or similar stick, a piece of 3/4 inch white pine 2 to 4 inches wide and about 12 to 16 inches long for a sighting stick, a piece of string, a fishing sinker (1/4 to 1/2 ounce), a protractor, a 3/16-inch bolt (2 1/2 inches long) with wing nut, two eye-screws (3/4 to 1 inch in diameter) and some brads. Use Figure 3 as a guide.

First, drill a hole through the middle of your sighting stick large enough to accommodate the wing nut bolt. Next, drill a second hole of the same size through the top of the broom stick. Place two eye-screws into opposite ends of the sighting stick so you can sight through both. To one side of the sighting stick, fasten the protractor firmly. Drive a brad (nail) halfway in at the center of the diameter line of the protractor. On this brad, hang the string with a weight at the other end.

Push the bolt through the hole in the broom stick and then the sighting stick and put the wing nut on. (If a camera tripod is available, you may wish to use it instead of the broom stick, but mounting it will be slightly different.)

The launch range section of this project will tell you where to set up the tracking scope in reference to the launching pad. Push the broom stick into the ground far enough to make the tracking scope stable.

Using this tracking scope is very simple. First, the distance between your launch pad and tracking scope when they are set up is known as the *baseline*—for example, 300 feet. Second, when the rocket is launched, it will fly upward to its peak and arch over to return. The person or crew at the tracking station will follow the rocket through the two eye-screws to its peak and then lock the tracking scope in that position. Third, the string with the weight on it will line up with a

certain degree on the protractor. In this example, we will use 30 degrees. The tracking crew will inform the launch recorder that the reading is 30 degrees. The launch recorder will turn to the tangent chart in the back of this guide and find the tangent for 30 degrees, which is .58. The recorder will then multiply .58 by 300 feet, which is the baseline, and come up with 174 feet of altitude. This is the approximate altitude the rocket reaches.

Figure 3. Tracking Scope

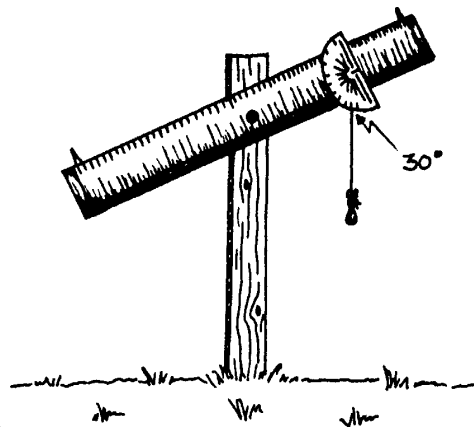

(Multiply Baseline by Tangent)

(30 = .58)

|          |                      |
|----------|----------------------|
| Baseline | 300 feet             |
| Tangent  | <u>x .58</u>         |
| Approx.  | 175.00 feet altitude |

## Building Your Model Rocket

There are many model rocket styles to choose from. Your leader can help you choose one. Most kits have a good set of easy-to-understand instructions. *Follow them.*

Here are a few additional pointers:

- Before you cut your fins, be sure the grain of the wood is going the right way. Your instructions will tell you which way is right. Then sand the front edge to make it rounded and sand the trailing edge of the fin to a sharp point (see Figure 4).
- Take a root edge of a fin (the root edge is the edge that goes onto fuselage) and place it in a pool of glue. Put it on the rocket and hold it for 15 seconds. Take off and dip again. Hold the fin with root edge attached to the rocket until glue is stable.

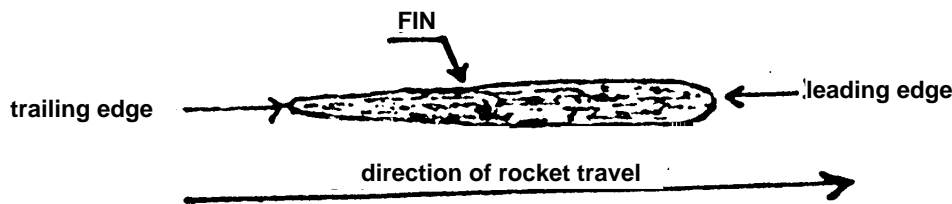

Figure 4. A simple rocket model

- When painting your model, remember that the glossy smooth rocket will go about 60 percent higher than the same rocket given a rough paint job. Some people even put a coat of wax on their rockets after they are painted and dry to make the surface even smoother.

The main thing in assembling your kit is to take your time and follow instructions.

The rocket illustrated in Figure 5 is a commonly constructed example, but you should follow the plans that come with your kit, as it may vary somewhat.

The NOSE CONE (A) is the top of your rocket and is streamlined to some extent. It is usually made of balsam wood. The BODY (B) is made of a cardboard or light plastic tube. The FINS (C) are of balsam or plastic. They keep the rocket stable in flight. Great care should be taken in shaping and mounting the fins.

When the rocket body is larger than the engine, ADAPTER RINGS (D) are used to fit the rocket body to the ENGINE TUBE (E). The engine tube is where you put the engine.

Shown in Figure 5, there are two methods of fastening engines in the engine tube. (Your rocket will use only one method.) A spring steel ENGINE HOLDER (F) is placed against the engine tube. The upper hook of the steel holder extends into the engine tube. The holder and engine tube is then

wrapped with TAPE (G). The engine can be slipped into the tube by pulling the spring steel holder back and allowing it to reset itself when the engine is inserted all the way.

The other method is just to glue an ENGINE RETAINING RING (H) inside the top of the engine tube. A few layers of tape are wrapped around the engine so that it fits snugly when inserted.

FIREPROOF WADDING (I) is used to protect the recovery system from the hot gases of the ejection charge. Four-inch square sheets of fireproof crepe paper can be used.

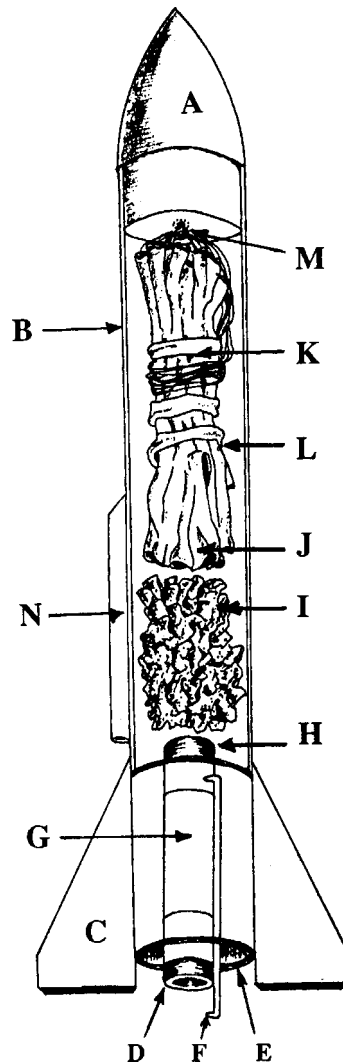

Figure 5. A model rocket illustration

The recovery device shown is a rolled-up plastic PARACHUTE (J). SHROUD LINES (K) are tied to the chute and to the EYE SCREW (M). Fastened to the eye screw also is the SHOCK CORD (L). The other end of the shock cord is fastened to the rocket body.

To keep the rocket stable during launch, a LAUNCH LUG (N) is used.

## The Rocket Engine

The rocket engines you will use are manufactured by machines. An engine is taken from the assembly line regularly and tested to see that it meets company specifications and federal regulations. See Figure 6.

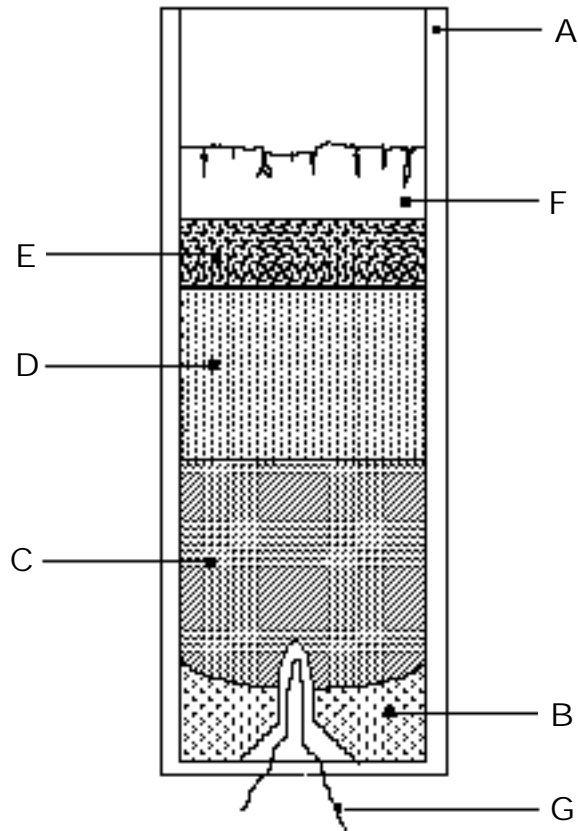

Figure 6. Enlarged Rocket Engine

The engine starts with a rolled PAPER CASING (A). A CERAMIC NOZZLE (B) is added to the back end. The hole in the nozzle is where the gases exit the engine and propel the rocket. The PROPELLANT CHARGE (C) is the actual compound that launches the rocket. The formula for this compound is kept secret by the different companies manufacturing engines. When the propellant is consumed, it starts the DELAY AND TRACKING CHARGE (D) burning. This compound burns slowly to give the rocket time to coast upward; smoke is given off to enable you to track the rocket better. When the delay charge is consumed, it fires the EJECTION CHARGE (E), which quickly builds up pressure inside the rocket body and activates or pushes out the rocket's recovery system. The ejection charge is a rapidly burning, large-grained compound held in place by a paper RETAINING CAP (F). The action of the ejection charge is really more like a mild explosion.

All model rockets are fired electrically for safety reasons. (This also keeps them out of the fireworks category.) An IGNITER WIRE (G) is used and is placed into the cavity of the propellant charge as illustrated in Figure 6. (The different parts of the rocket engine illustrated can be labeled and colored with pencils.)

Engines have varying degrees of power and are classified A, B, C, D, E, and F. The A engines give you a choice of a weak 1/4 power, a stronger 1/2 power, or the full A engine. The B size is more powerful and the F size is the most powerful. (Each letter is twice as powerful as the one before.) You will be concerned with engine sizes 1/4 A through C. Be sure to use the engine suggested for your rocket.

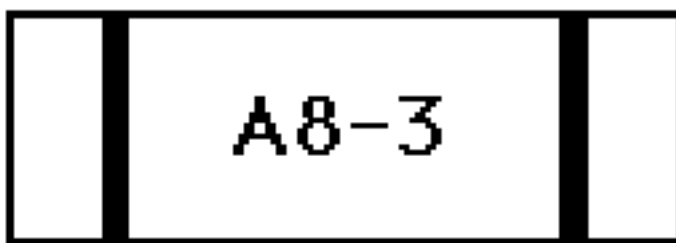

Figure 6a. Power "A" Type Rocket Engine

The engine in Figure 6a is an "A" power engine. What does the 8-3 mean? The first number is the average thrust in Newtons (a unit of measure; 4.54 Newtons equals 1 pound of force). In this case the thrust is 8. The number after the hyphen is the time delay in seconds before the recovery system will be activated. In this case, it is 3 seconds. For more information on engines, read the data sheets supplied with most engines.

## Recovery Systems

Safety rules require that your rocket have a safe recovery system to prevent the rocket from descending too swiftly. There are three main types of recovery methods, and all are activated by the ejection charge of the engine.

1. The most popular method is the parachute. Upon being ejected from the rocket, it unfolds and permits a slow and safe descent. You will probably have to chase your rocket a bit farther with this method because the wind will carry it downrange.
2. The next most popular is the streamer system. The streamer is a strip of crepe paper from 1/2 to 2 inches wide and up to 3 or more feet long. When ejected from the rocket, it unrolls and provides enough drag to slow the descent.
3. Another method used mainly on smaller rockets is to alter the balance, or aerodynamic design, of the model. This can be done in several ways. The ejection charge can blow the nose cone out and

destroy the streamlining, causing it to tumble back down slowly and safely. These two methods are tumble recovery systems.

Another way is to design the rocket so that the ejection charge will push the engine casing back towards, but not out of, the end of the rocket, changing the balance. This will not let it fly, so again it tumbles down slowly and safely.

One more reason for recovery systems is that you will be able to reload and repack the rocket you just recovered and launch again and again.

### Launching Your Rocket

Fins on a rocket are different in design and purpose than those on an airplane. Rockets are designed to fly vertically and not horizontally. Therefore, with your launch pad level on the ground, your rocket will be launched straight up, which is 90 degrees. If you wish to launch at a slight angle (keeping in mind that 30 degrees from the vertical is maximum permissible) place a small block under one side of the launch pad.

After the engine is installed in the rocket, the recovery system can be checked and packed. The igniter wire (see rocket engine chart) can be bent and installed deep enough into the rocket engine nozzle to be certain of ignition. To keep the igniter wire in place and to keep the igniter from shorting out, spread the two ends and place a BB-sized piece of fireproof wadding between the wires and into the throat of the nozzle.

The rocket can now be placed on the pad by inserting the launching rod through the launching lug and sliding the rocket down to the bottom. After connecting one clip to each end of the igniter wire, you are now ready to take command of the launching panel. You can now turn to the Launch Day section of this unit.

## Launch Day

### ***Launch Personnel and Their Duties***

RSO—The Range Safety Officer is a responsible adult, usually the club leader, in charge of the entire project. The RSO's duty is to see that all safety procedures are followed during launch days. The RSO has the power to hold, postpone, or completely refuse to OK any rocket felt to be unsatisfactory until the fault is corrected. The RSO will call attention to the model to be launched and the name of the builder.

FC—The Flight Commander is the rocket builder and is in charge of loading and firing the rocket. (Each member in turn becomes the FC for their own rocket.) The FC has the right to call a hold in the countdown if trouble develops. After launch and recovery, the FC moves to a new position on the Recovery Team.

LR—The Launch Recorder is a club member who records another member's launch. After the launch and recovery, the LR signs the record sheet and then assumes a new position as FC.

CD—The Communications Director is a club member who keeps the trackers and recovery crew in touch with the launch control center. The CD can call a hold in the count-down if trouble develops. In smaller clubs the LR and CD's jobs can be handled by one member. In larger clubs they are separate and the CD then becomes the new LR. The RSO may have the job of announcing the launches and their builders.

TC—The Tracking Crew can be one, two, or three club members situated where they can track the flight of a rocket, mark its angle, and report the angle to the CD at LC(Launch Control). The TC can call a hold if they develop trouble at their station. The number one tracker (if there is more than one) moves next to CD. Number two becomes number one, three becomes two, and the new tracker is number three.

RT— The Recovery Team consists of the rest of the club scattered downrange to watch for and locate the rocket launched by another member. The RT is not permitted to touch or disturb the recovered rocket unless Launch Control gives permission to do so. It is their job to be ready at all times. The rotation is the same as for TC.

LCC—The Launch Control Center is the area containing the RSO, the FC, the LR, the CD, if any, and the launch panel. (Can also be called Mission Control.)

When choosing and setting up your launch range, there are several things you need to consider. Use Figure 7 as a model for setting up your launch range.

First, the launch range has to be as large and as flat as possible. Size depends on the size of the rocket engines being used. If everyone is using low power engines, the field size should be about four or five hundred feet square. For the larger engines, you should have about a half mile square. If you have the large field, you are set for both launches. Don't forget to get permission to use the field first and don't destroy private property. Choose a range that is easy to get to. Farms and airstrips not in use are good places to start checking.

If your launch range is limited, as most will be, you must position everyone carefully.

A weather team can be appointed to find out which direction the wind is blowing. This can be done by cloud watching, putting a streamer on top of a very high pole, or just tossing aloft a stone wrapped in paper in the hope that as it gets up it will unwrap. The stone will come sailing back down (watch out) and the paper will float in the wind.

With the wind direction known, downwind—or the direction the wind is blowing—is downrange and upwind is uprange.

One-fourth of the distance downrange, in the center of the workable space, is where to locate the launch pad. Go back uprange one-half of this distance and make a 90-degree turn left or right (depending on which point will be better for setting up the tracking station). Now, mark off 100 feet for small rocket engine launches and 300 feet or more for large engine launches. *This distance will be the baseline for finding altitudes attained by your rockets.* Set your tracking scope here.

The launch control center will be about 20 feet from the pad. Set it up so the FC can follow the rocket downrange.

The recovery crew is spread out at different points downrange (RT-1, RT-2, etc.). They should be situated where they will have unobstructed visibility.

### *Communications*

A good means of communication is going to be needed between Trackers, Recovery Team, and Launch Control Center. Walkie-talkies are recommended because of the ease in setting them up. Good walkie-talkies are expensive but might be borrowed if some members do not already have them.

Telephones or intercoms that use wires for hookup are a second choice, if available. Remember to lay wires so members and spectators will not trip over them. Runners may be set up between stations, or members can just shout from one point to another.

### A Typical Good Launch

Here is a typical good launch starting right from the range.

After selecting a good field for the launching range, you must set up your launching day. Be sure you select an alternate date in case of bad weather. If the launch is to be open to the public, inform the newspapers one or two weeks in advance.

On the scheduled day, arrive early to set up range. Those launching a rocket should be given a number. Number one will be first to launch, number two will be the LR first and then move in turn to LC, etc. The RSO is checking safety but will assist if members get stuck.

First, a team should find the direction of the wind and move the equipment to the *upwind* section of the field, near the middle (use Figure 7 as a guide).

The pad can be set in place with the safety flag on it, and its wire run from the control panel (LCC). Run the power wire to the car battery. It would be convenient to obtain a card table or two to set up as the LCC. Decide where the LR, the FC, and the CD, if any, are to sit.

The tracker can measure off the distance into the wind from the pad and make a left or right turn *across* wind for the distance decided upon. The tracking scope is set up at this point. It is advisable to set up the tracking scope so the sun is at your back as much as possible as you follow the rocket.

Mark off sections for spectators to sit. Again, try to have their backs to the sun so they can have a good view of the launches and returns.

Set up and/or check out the communications to be used for the day. Everyone can leave their workbooks and launch record sheets, with the top section filled in, at the LCC.



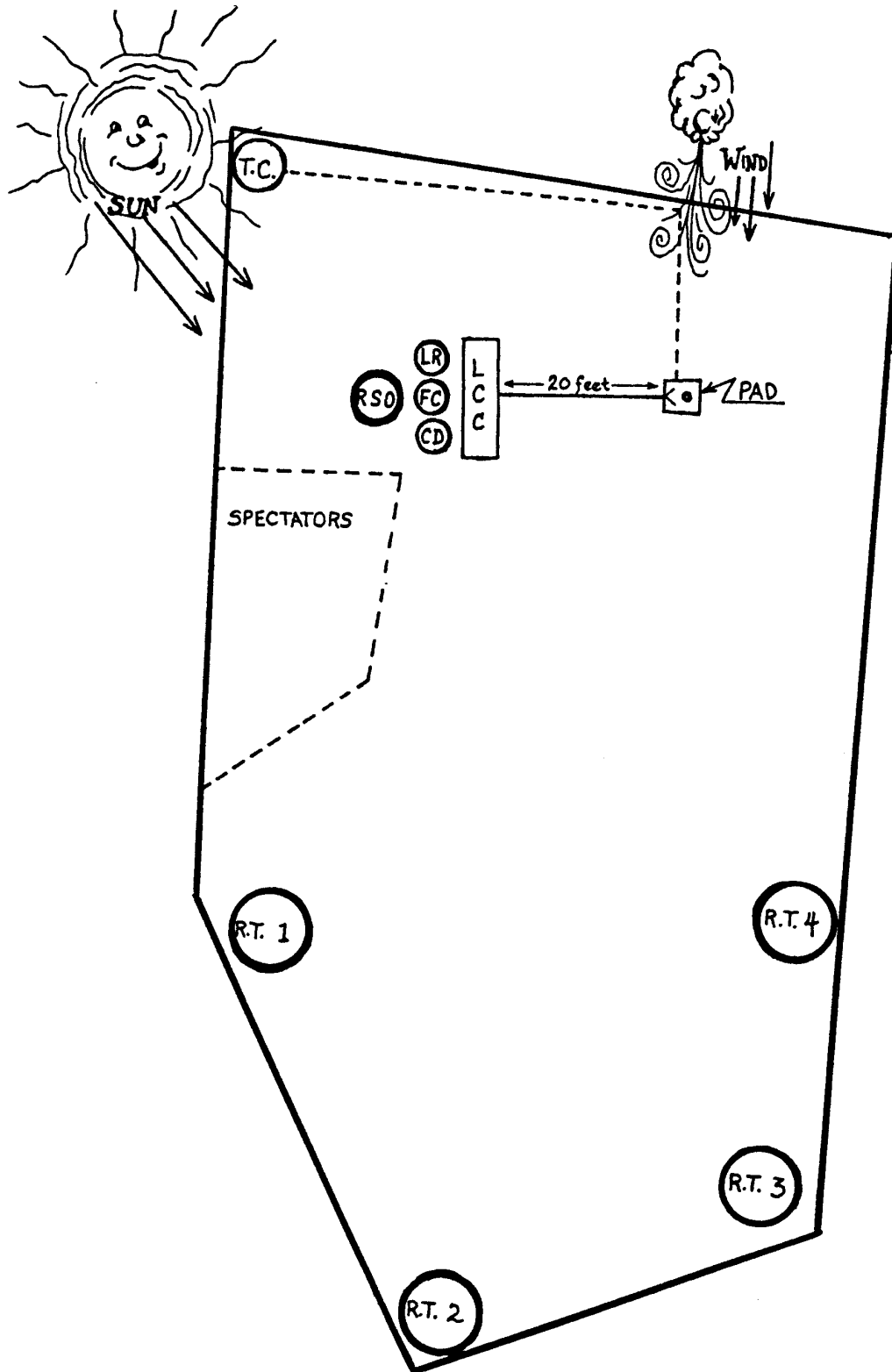

Figure 7. Model Rocket Launch Range

The recovery team can be spread out downrange so they each have a good vantage point. The other members can take their positions. It's time to begin.

The LR takes the launch record sheet that belongs to the FC and signs or initials the first space. (The top section has already been completed by the FC.) The LR then fills in the date of launch; engine use; total weight, if known; angle of launch; wind speed and direction; and temperature and visibility. The tracking officer can sign before or after the launch.

The LR now reports he is GO and puts a check in the proper space.

While the LR was filling in the spaces, the FC has been packing the recovery system and inspecting and installing: the engine, and the igniter wire. Then the FC reports "Rocket is GO" and the LR checks the space.

The FC places the rocket on the pad, makes the electrical connections, and reports "Pad is GO."

The tracking crew reports "Tracking is GO."

The recovery crew reports "Recovery is GO."

Everyone at LCC is ready, so "LC is GO."

The "Range is GO" and the RSO gives the key to the FC. The FC inserts the key, turns the panel on, and reports "All systems GO for launch."

The CD or RSO counts "T-minus 5-4-3-2-1-Ignition." On ignition, the FC pushes the button and the rocket soars off the pad. Being aerodynamically designed and balanced, it will arch into the wind somewhat. The LR keeps track of the "time." The tracking station off to the side tracks and follows the rocket all the way up to the highest point of its flight. They lock the tracking scope at that position. The recovery device deploys and the LR has already checked "Lift-off has occurred" and is now checking "Recovery system is GO." The recovery team keeps their eyes on the descending rocket as the wind carries the rocket downrange closer to them. The TC (tracking crew) calls in the angle they read off the tracking scope. The LR fills in the space and converts it to the tangent. The LR then figures out the altitude and fills in that space. The estimated duration of the flight (from lift-off to touch down) is figured and filled in. The flight performance is judged poor, fair, good, or excellent.

The RSO initials his space and reclaims the key. After the rocket is brought back to LCC everyone rotates to the next position and makes ready for the next launch. The RSO will help everyone rotate so all get a chance at each position. Good luck.

---

---

## 4-H Launch Record Sheet

Flight commander \_\_\_\_\_

Rocket name or number \_\_\_\_\_ Weight empty \_\_\_\_\_

Rocket colors \_\_\_\_\_ Recovery method \_\_\_\_\_

Date completed \_\_\_\_\_ Completed dimensions \_\_\_\_\_

**LAUNCH NUMBER**

**No. 1**

**No. 2**

**No. 3**

**No. 4**

Launch Recorder (LR) \_\_\_\_\_

Tracking Officer (T.O.) \_\_\_\_\_

Date of launch \_\_\_\_\_

Engine used \_\_\_\_\_

Total weight \_\_\_\_\_

Angle of launch \_\_\_\_\_

Wind velocity & direction \_\_\_\_\_

Temperature & visibility \_\_\_\_\_

Launch Recorder is GO \_\_\_\_\_

Rocket is GO \_\_\_\_\_

Launch pad is GO \_\_\_\_\_

Tracking is GO \_\_\_\_\_

Recovery is GO \_\_\_\_\_

Launch Control is GO \_\_\_\_\_

Range is GO \_\_\_\_\_

All systems GO for launch \_\_\_\_\_

T-minus 5-4-3-2-1-Ignition \_\_\_\_\_

Lift-off has occurred \_\_\_\_\_

Recovery system is GO \_\_\_\_\_

Tracking reports (degs.) \_\_\_\_\_

Computed altitude \_\_\_\_\_

Flight duration \_\_\_\_\_

Flight performance \_\_\_\_\_

RSO initials \_\_\_\_\_

## 4-H Model Rocketry Quiz Unit One

Identify the parts:

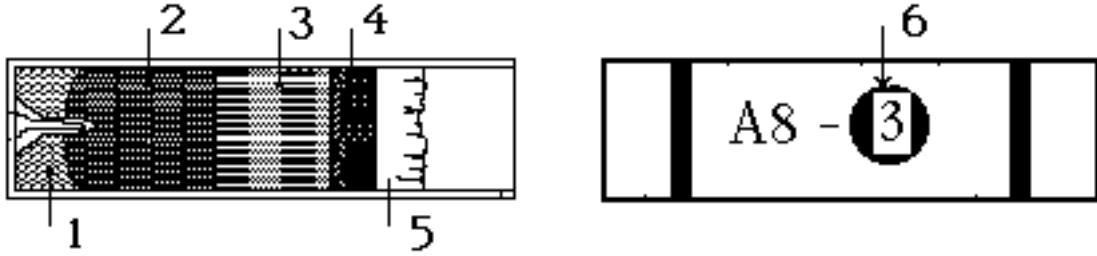

- |          |          |
|----------|----------|
| 1. _____ | 4. _____ |
| 2. _____ | 5. _____ |
| 3. _____ | 6. _____ |

Answer the following questions—Club leader will provide the questions:

7. \_\_\_\_\_
8. \_\_\_\_\_
9. \_\_\_\_\_
10. \_\_\_\_\_
11. \_\_\_\_\_
12. \_\_\_\_\_
13. \_\_\_\_\_
  
14.      B4 - 2                      B6 - 4                      B14 - 5                      B6 - 6
15. \_\_\_\_\_

True or false? Club leader will provide the questions:

- |           |           |
|-----------|-----------|
| 16. _____ | 21. _____ |
| 17. _____ | 22. _____ |
| 18. _____ | 23. _____ |
| 19. _____ | 24. _____ |
| 20. _____ | 25. _____ |

Possible score is 25 points. Points achieved in this quiz: \_\_\_\_\_

## My 4-H Rocketry Project Report

Write a brief summary of what you learned from this project. Describe any particular problems that you encountered and how you solved them. What does 4-H model rocketry mean to you?

## Angles and Tangents

| Angle | Tangent | Angle | Tangent | Angle | Tangent | Angle | Tangent |
|-------|---------|-------|---------|-------|---------|-------|---------|
| 1     | .02     | 23    | .42     | 45    | 1.00    | 67    | 2.36    |
| 2     | .03     | 24    | .45     | 46    | 1.04    | 68    | 2.48    |
| 3     | .05     | 25    | .47     | 47    | 1.07    | 69    | 2.61    |
| 4     | .07     | 26    | .49     | 48    | 1.11    | 70    | 2.75    |
| 5     | .09     | 27    | .51     | 49    | 1.15    | 71    | 2.90    |
| 6     | .11     | 28    | .53     | 50    | 1.19    | 72    | 3.08    |
| 7     | .12     | 29    | .55     | 51    | 1.23    | 73    | 3.27    |
| 8     | .14     | 30    | .58     | 52    | 1.28    | 74    | 3.49    |
| 9     | .16     | 31    | .60     | 53    | 1.33    | 75    | 3.73    |
| 10    | .18     | 32    | .62     | 54    | 1.38    | 76    | 4.01    |
| 11    | .19     | 33    | .65     | 55    | 1.43    | 77    | 4.33    |
| 12    | .21     | 34    | .67     | 56    | 1.48    | 78    | 4.70    |
| 13    | .23     | 35    | .70     | 57    | 1.54    | 79    | 5.14    |
| 14    | .25     | 36    | .73     | 58    | 1.60    | 80    | 5.67    |
| 15    | .27     | 37    | .75     | 59    | 1.66    | 81    | 6.31    |
| 16    | .29     | 38    | .78     | 60    | 1.73    | 82    | 7.12    |
| 17    | .31     | 39    | .81     | 61    | 1.80    | 83    | 8.14    |
| 18    | .32     | 40    | .84     | 62    | 1.88    | 84    | 9.51    |
| 19    | .34     | 41    | .87     | 63    | 1.96    | 85    | 11.43   |
| 20    | .36     | 42    | .90     | 64    | 2.05    |       |         |
| 21    | .38     | 43    | .93     | 65    | 2.14    |       |         |
| 22    | .40     | 44    | .97     | 66    | 2.25    |       |         |

Angles greater than 85 degrees are extremely high error possibilities and are not dependable. If you are getting angle readings in this area, you should increase the baseline distance.

## My Model Rocket

Mount one or more photographs of your rocket in this space.



Model rocket manufacturers can be found in the classified ad sections of magazines such as *Popular Science* and *Popular Mechanics*.