

# Flexies— The Choice of Champions?

## A Simple How-to on Flexie Construction

By Craig P. Beyers

The flexie—the Rogallo or flex-winged glider—has the distinction of being, depending on your viewpoint, either a fantastically-successful glider design, or grossly unfair. The achieved performances of these designs have often been significantly better than the performances of more orthodox balsa-winged gliders.

It seems as if interest in flexies was piqued by the performances of the Opel flexie at the Third World Spacemodeling Championships in Czechoslovakia in 1978—at least it seemed that way here on the East coast. A number of people, notably Charlie Sykos, the Heaton brothers, and John Kalyan, have flown flexies with great success. One of the more energetic designer/developers of flexies is George Gassaway, whose *Windrift* designs have performed very well, earning George a place on the US Team at the Fourth World Spacemodeling Championships at Lakehurst, NJ. The discussion and drawings that follow are the result of George's hours of designing and test-flying flexies, and represent one state-of-the-art in flexie design in the US.

The basic *Windrift* flexie has four major parts: the spars, the spring, the covering, and the booster.

### Spars

All three spars should be the same length and should be sized as shown in Table 1.

Table 1. Spar Dimensions and Spring Wire Diameter for Flexies

Engine Rating	Music Wire Spring Diameter (inches)	Spar Length (inches)	Spar Material and Dimensions (inches)
¼A	0.015	10-12	1/16 x 1/8 spruce*
½A	0.015	12	1/16 x 1/8 spruce*
A	0.015	12-14	1/16 x 1/8 or 3/32 spruce
B	0.020	14-16	3/32 x 1/8 spruce
C	0.020	16-18	3/32 x 1/8 spruce
D	0.025	18-21	3/32 x 1/8 or 3/32 x 3/16 spruce
E	0.025-1/32	21-24	3/32 x 3/16 or 1/8 x 1/8 spruce
F	1/32-?	24-?	1/8 x 3/16 or 3/16 x 3/16 spruce

\*3/32" balsa can be used for ¼A and ½A events. These flexies will be lighter and will perform better, but will be more fragile.

### Spring

The spring is possibly the most important part of a flexie because it holds the spars together at the front, keeps the spars apart at the rear and the covering taut when the glider deploys, and gives some dihedral to the "wings" to provide roll stability. It is made from small diameter music wire (see Table 1) and is attached to the spars with glue and thread. Figure 1 shows the configuration of the spring. Form the coil by wrapping the music wire once around a piece of 3/32" (2.4 mm) diameter music wire. After the spring is attached to the spars, pull the spars into the flight position and tie a piece of thread to each spar to hold the spars in position so that you can attach the covering.

FIGURE 1:  
Spring Configuration (Full Size)

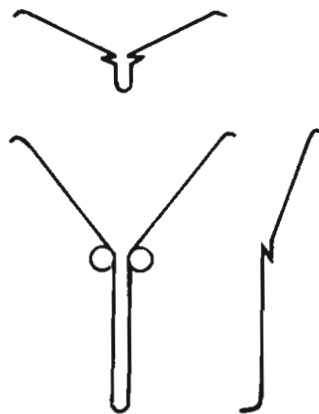

### Covering

George uses plastic (¼-mil, from dry cleaner bags), although others have used aluminized Mylar. Plastic has advantages over Mylar in that it can be easily glued to the spars with cyanoacrylates such as *Hot-Stuff*, and that it seems less susceptible to the heat from the ejection charge. It suffers in visibility compared to Mylar because it is transparent whereas the Mylar is highly reflective.

George started out using cyanoacrylates to attach the covering, but has recently switched to thinned contact cement. To make the covering, cut a square of your chosen material with sides equal in length to the length of the spars. Then cut the back diagonally to fit the center spar. Attach the covering first to the two side spars and then to the center spar. Try to keep the covering tight at the front and somewhat loose at the rear (so that it billows) to minimize the chance of death dives. Use thread to sew the covering to the spars for better retention (see Figure 2).

FIGURE 2:  
Stitching For Covering  
Attachment

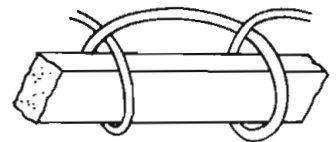

After the covering is attached, free the spars by cutting the restraining threads.

### Booster

In addition to a good glide, the successful flexie's performance depends on a straight stable boost and reliable glider deployment. Building a long booster with relatively large fins will ensure both. George recommends that the booster be long enough to allow about half the spar length between the engine and the glider when the glider extends from the front of the booster by 3" to 4" (76 mm to 102 mm—see Figure 3). For a 20" (508 mm) flexie, the booster should be about 29" to 30" (737 mm to 762 mm). The booster should be recovered by a small chute or streamer, and an external shock cord mounted to the root of one fin. No nose cone is used.

### Getting It Back

One of the disadvantages of flexies is that they're often hard to return, especially if the wind is blowing! One way of solving this problem is to use a dethermalizer to actuate a change in center of gravity (CG) at some predetermined time. The basic system for dethermalizing flexies includes some rubber bands, an extra spar hinged to the center spar with a model airplane hinge, the dethermalizer (DT) fuse, and a nylon

activating line. As shown in Figure 4, the pendulum spar is hinged to the center spar at the flexie's CG, and is held in position by two rubber bands and the nylon limit/activating line. During boost the pendulum spar is folded forward and protrudes from the booster.

When the flexie deploys, the rear rubber band pulls the pendulum spar to a vertical position at the CG. The forward rubber band and the limit/activating line ensure that this position is maintained during flight. When the DT fuse burns through the limit/activating line, the rear rubber band is released. The front rubber band then pulls the pendulum spar forward, changing the CG and causing the flexie to dive—and making it easier to find!

A major disadvantage of the pendulum DT is its inherent high weight compared to the non-dethermalized flexie. George has experimented with a different system that does away with the pendulum. Figure 5 shows how this design works. The spring for this design operates only on the center spar and *one* side spar. A rubber band attached between the other spar and an extension on the center spar pulls the spar open. When the DT fuse burns through the nylon limit/activating line, releasing the rubber band, air pressure folds one wing, causing the flexie to fall. This DT is faster and much lighter than the pendulum DT. According to George, some up-elevator warp and a bit of tail weight is needed to obtain a good glide. Note that the angle between the two outer spars in George's experimental configuration is 110° instead of the more usual 90°. This small change increases wing area by about 15% with a minimal increase in weight.

Proponents of flexies will continue to rave about the performance and opponents will continue to complain about "kites" and "parachutes" not being legal gliders in NAR competition. But flexies will be around for a while—unless the wind blows! So, get out your spars, plastic, and music wire, and build a few flexies. Maybe you'll be as successful as George!

**FIGURE 3:**  
Booster Configuration

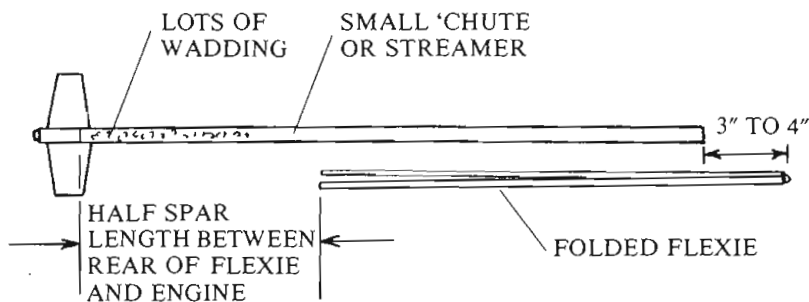

**FIGURE 4:**  
Pendulum DT

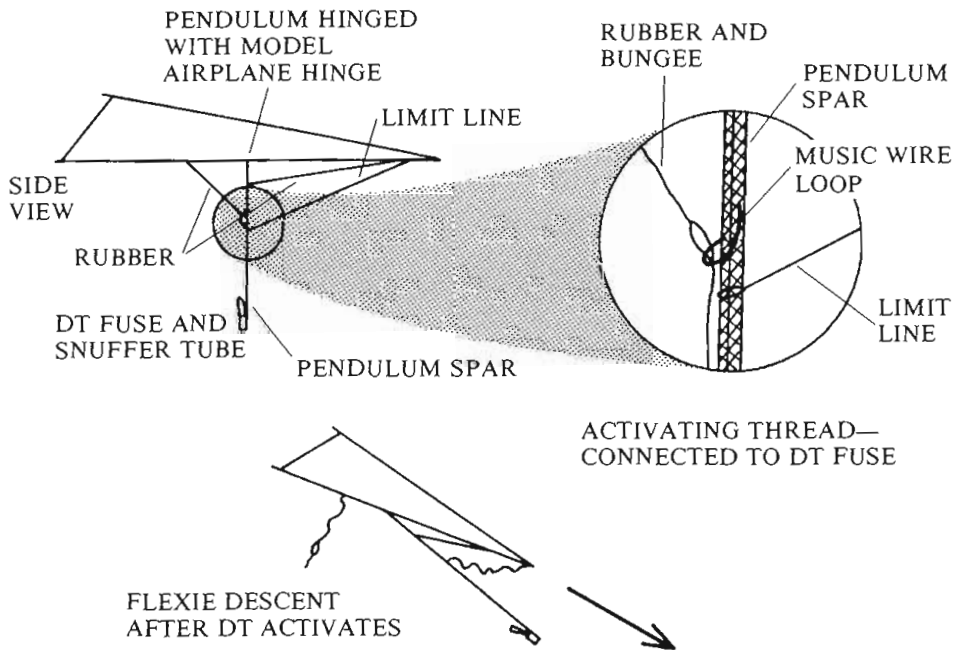

**FIGURE 5:**  
"Lame Duck" DT

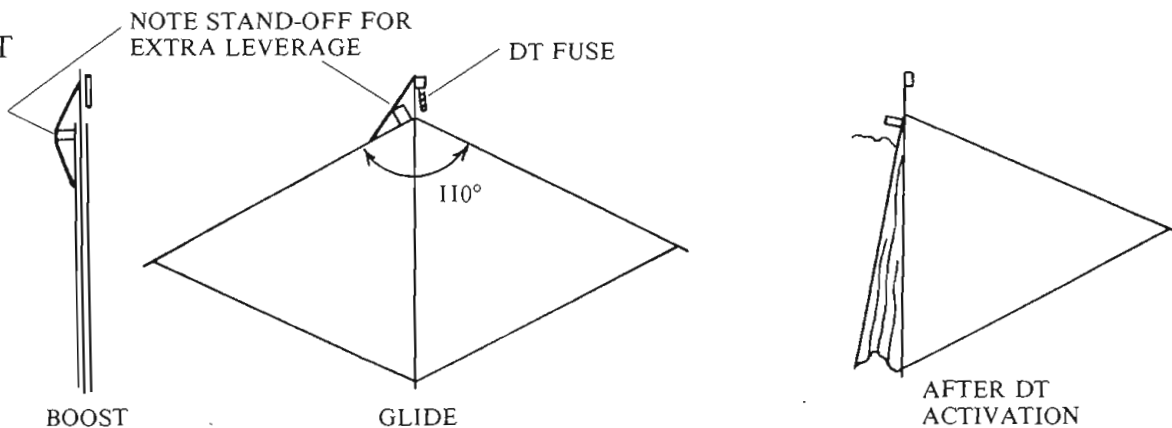

# Competition Plan

# WINDRIFT

by George Gassaway and Tony Williams  
from *Impact*

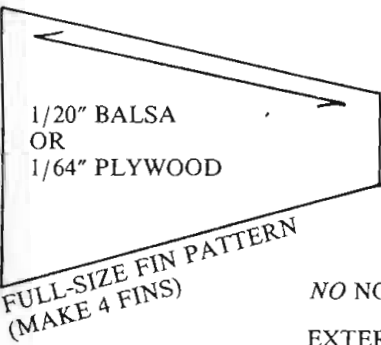

NO NOSE CONE

EXTERNAL SHOCK  
CORD MOUNTED TO  
FIN ROOT

1/16" x 1/8" x 12"  
SPRUCE SPARS

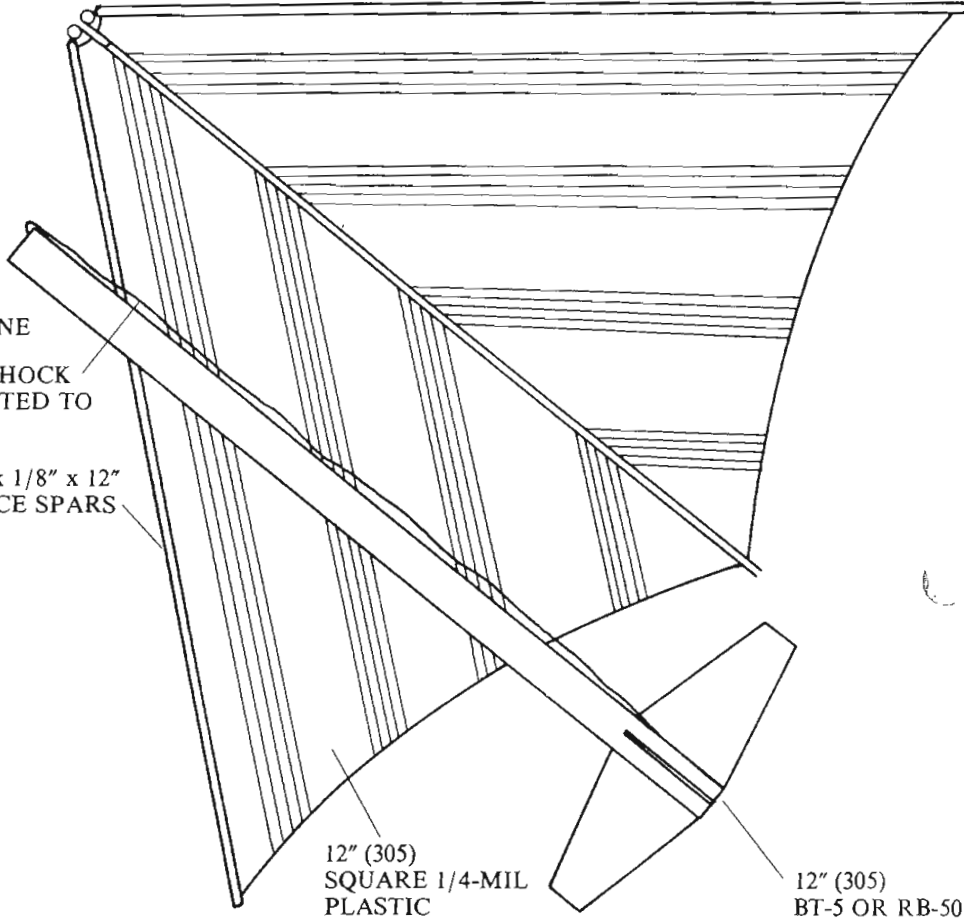

George Gassaway hooks up his Windrift entry in E Boost/Glider during the 1980 World Championships. The pods near the fins on the second stage hold streamers for the recovery of the first stage, an oddity required by the FAI rules' apparent failure to consider the possibility of boost/gliders with stages! (Photo by C. D. Tavares)

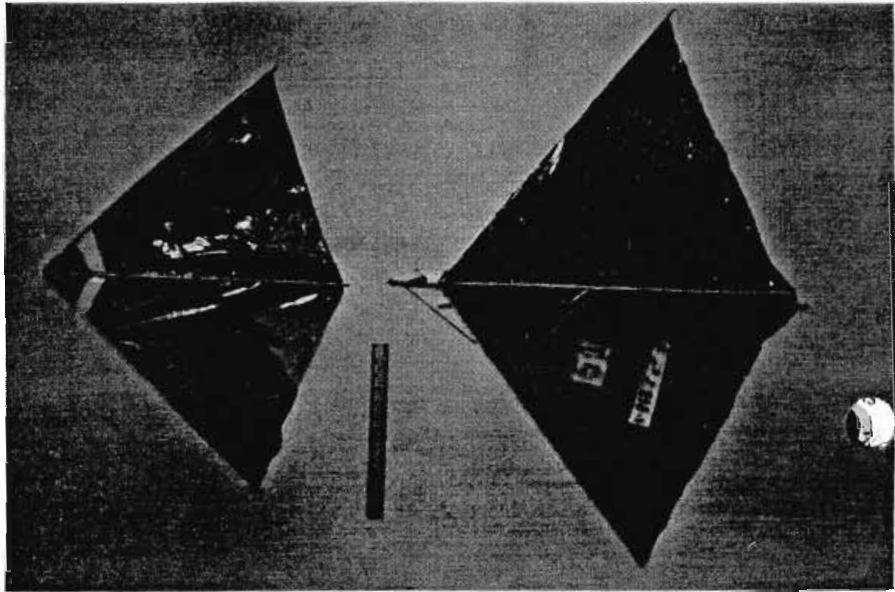

# HOW TO BUILD AND ADJUST FLEX-WING BOOST/GLIDERS

from **IMPACT**by **George Gassaway**

Some persons have had trouble building "contest quality" flex-wings and getting them to glide properly. The following is a discussion of the assembly and adjustment methods that have been developed over the last few years. For information on the basic flex-wing design, refer to the "Windrift" article in the December 1980 Model Rocketeer. (If you do not have that issue, a copy of the magazine may be obtained by writing to NAR Technical Services, PO Box 330267, Ft. Worth, TX 76163-0267)

Please note that these assembly and adjustment methods alone do not guarantee that every flex-wing will turn out well. It is best to plan on building several flex-wings and choose the best ones to fly in competition. (That's just the way it is.) The poor ones can be re-covered or used as sport and demonstration models.

First off, I will assume you have the framework properly assembled. This means the spring is securely in place with many wraps of thread and glue to hold it to the spars, and the spar ends are all touching the spring coils. Some people have built frameworks with the spars separated from the coils and have lost a lot of spring action as a result. Study the "right" and "wrong" examples of assembled frameworks in Figure 1.

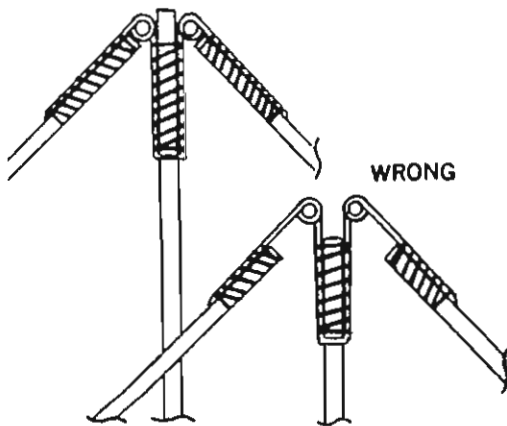
**RIGHT****Figure 1.**

The key to faster and more accurate assembly is use of a combination cutting/building board. This can be nothing more than a large piece of cardboard. (Bicycle boxes are good sources.) The cardboard is cut large enough to hold the largest flex-wing you plan to build. Lines are drawn on it to represent the locations of the spars, using whichever nose angle you prefer (90 degrees, 110 degrees, etc.). Then the lines for the trailing edges are

marked off, usually in one- or two-inch increments as measured by the spar lengths. A range of 10 to 24 inches should cover just about any size flex-wing you would ever want to build. (See Figure 2). (You may want to mark off the opposite side of the board with different parachute outlines for fast cutting of competition 'cleaner bag' type 'chute canopies.)

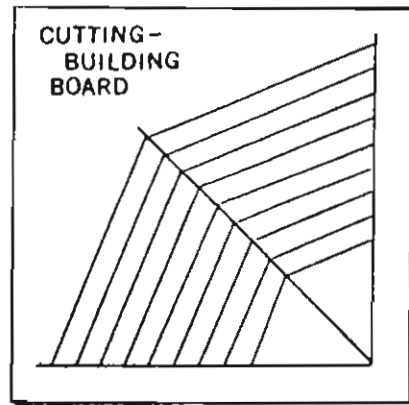
**Figure 2.—Lines are drawn on the board to represent spar and plastic locations.**

Small pieces of double-sided tape (or strips of masking tape formed into flattened tubes with the adhesive side on the "outside") are stuck to the board in the appropriate locations to securely hold it. The locations should be at all four corners of the outline of the flex-wing size you will be building, and also at least four places outside the outline (Figure 3). The pieces of tape should be rubbed with some cotton or even lightly dusted with talc to reduce the tape's stickiness so that the plastic will be held in place but not so strongly that it will be ripped when you try to remove it from the board.

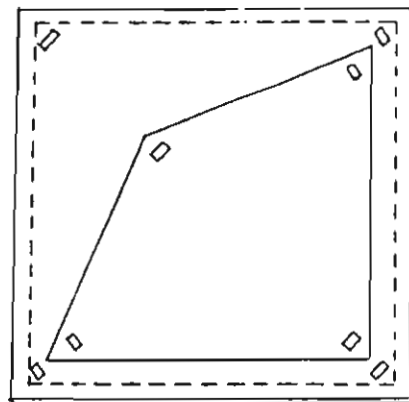
**Figure 3.—Attach plastic to with tape "loops" at all corners.**

Next, lay the plastic onto the board and use the tape points to hold it in position. Use a felt-tip marker to mark the center spar line onto the plastic, then cut the plastic along the side spar and trailing edge lines. Remove the excess plastic, but leave the flex-wing's plastic on the board. The framework will be attached to the plastic while it's still taped down.

Use thread to tie the framework spars back in an angle that matches the spar locations drawn on the board (Figure 4). Now use contact cement thinned with dope thinner to coat the upper surface of the left spar. (As always, exercise caution when using contact cement and thinner as the fumes are harmful and flammable.) Turn the framework upside-down and lay the left spar down on top of the right side of the plastic. After the cement starts holding the spar and the plastic together, carefully apply contact cement to the right spar and press it down onto the left side of the plastic. The spars should be attached to the plastic in such a manner that once removed from the board the plastic will be stretched tightly in front and is loose in the rear for proper billowing. With some experience you will learn how to do this reasonably well.

Before attaching the center spar, carefully remove the partially-built flex-wing from the board, with attention to not tearing the plastic. (Scrap balsa can be useful in separating the tape from the plastic.) Once removed, hold inverted and apply thinned contact cement to the center spar. Carefully lay the flex-wing back on the board with the plastic lying along the centerline previously marked on the plastic. While doing this, check to see there are no major wrinkles and that the proper amount of nose tightness and rear looseness is developing. Cut and remove the restraining threads, as they are no longer needed. Test glide the model indoors since it's often possible to adjust the plastic before the contact cement dries completely.

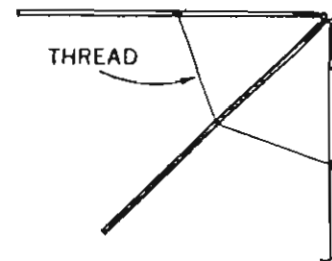
**Figure 4.—Use thread to secure the spars in the proper position.**

There are a few types of problems many flexies will have which you may be able to correct after assembly. Other problems will avoid all cures and will require removal of the plastic and a complete recovering job. As said before, for proper pull-out and glide the flex-wing should have the plastic stretched tightly in front and loose in the rear (See Figure 5). This allows the plastic in the nose to be at a higher angle of attack than the rear section, allowing the nose to act as a canard. If your flex-wing doesn't have the proper amount of billow in the rear, it could have problems with death-diving or poor glide performance. One effective solution to this problem is to pull in some of the plastic in front so that the rear has more billow. Strips of adhesive mylar, about 3/8" wide by 1-1/2" long, can be used around each spar about 1/4 to 1/3 back from the nose to tuck in some of the plastic (Figure 6). This takes care and practice to do properly; fortunately you can usually remove the mylar and try it again. Just be sure that the mylar can never accidentally stick to other areas of the plastic and thus prevent deployment.

Some flexies will have severe stalling that is difficult or impossible to trim. Sometimes they need so much noseweight that they are prone to trailing-edge-flutter death-dives if deployed pointing downward. These flex-wings usually have too much billow. The cure for this is to stretch the plastic in the nose

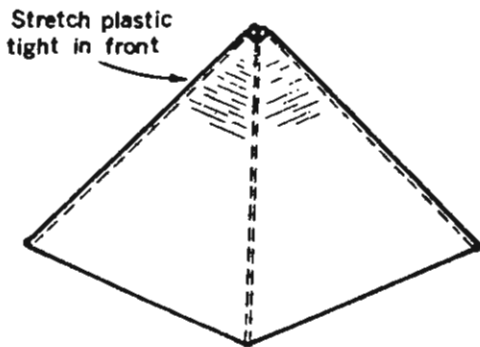

Figure 5.—The plastic should be tight at the front and "billowy" at the rear.

enough so that the billow is permanently reduced. Sometimes this works but sometimes it doesn't.

Finally, some flex-wings with nose-mounted dethermalizers will have a slight dive due to a bit more forward CG. First try to warp up the last 1/3 of the center spar for an elevator effect. This will often be enough. If not, add tail weight to balance it out. Clay will easily fall off, so simply Hot Stuff™ scrap spruce on to the spar as tail weight.

Note that you aren't through yet. See, the test glides are to determine if your flexie is good enough to justify completion. If it passes

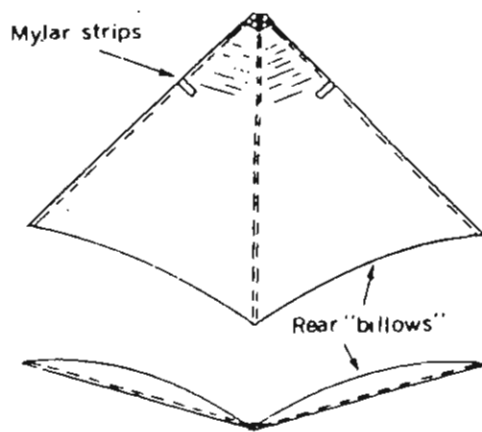

Figure 6.

the tests, you need to sew the plastic to the spars to insure it won't eventually come off. (Contrary to popular belief, contact cement alone will NOT bond the plastic to the spruce spars permanently!!) Color the plastic covering with felt-tip markers (some types do work better than others, so you might have to experiment with different brands). Don't forget to rig up a good D.T. if you ever plan on getting it back after its first flight!

Good building and good luck!

NAR OFFICIAL CERTIFICATION LABORATORY

MODEL ROCKET ENGINE TESTING REPORT

Manufacturer and Type: VULCAN E26

Type Certification Granted: Safety

Type Certification Granted: Contest

Certified Total Impulse (N-Sec): 40.00

Propellant Type: Composite

Casing Diameter (MM): 24

Date Effective: July 1, 1986

Date Effective: Aug 1, 1986

Delay Times: 5, 7, 10

Propellant Mass (GM): 19.2

Casing Length (MM): 85

----- STATIC TEST DATA -----

Number Tested: 16

Casing Date Codes: June 1986

Date Tested: June 1986

Test Temp (°C): 23 Elevation (FT): 50

Total Impulse (N-Sec): 39.54

std. deviation: 0.51

Peak Thrust (Newtons): 35.31

std. deviation: 0.71

Burn Time (Seconds): 1.41

std. deviation: 0.04

Casing Burnt Mass (GM): 36.2

Max Casing External Temp (°C): under 150

Delay Time (Sec)	5	7	10
Initial Mass (GM)	58.2	59.4	60.0
Avg. Measured Delay	5.53	6.92	9.17

Thrust-Time Curve:

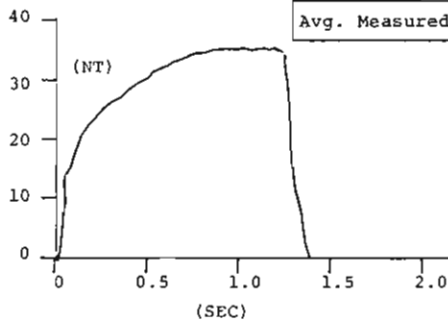

*John Kane*  
Committee Chairman

**RocketTip:** There is a variety of strong but thin plastic trash bags in several colors that are useful for large parachutes or streamers.

# Model Aviation Magazine

The AMA is offering its official publication to NAR members at the special rate of \$16 per year. This magazine covers every aspect of the model aircraft hobby as well as the most recent AMA news. NAR members can take advantage of this offer by sending \$16 check or money order to (made payable to NAR):

**Model Aviation Offer**  
182 Madison Drive  
Elizabeth, PA 15037.

This offer is only to NAR members and must be directed to the above address. Allow 6-8 weeks for delivery of first issue.