

Maxima 1/2A-A Glider v1.0

Copyright 1994, Apogee Components, Inc.

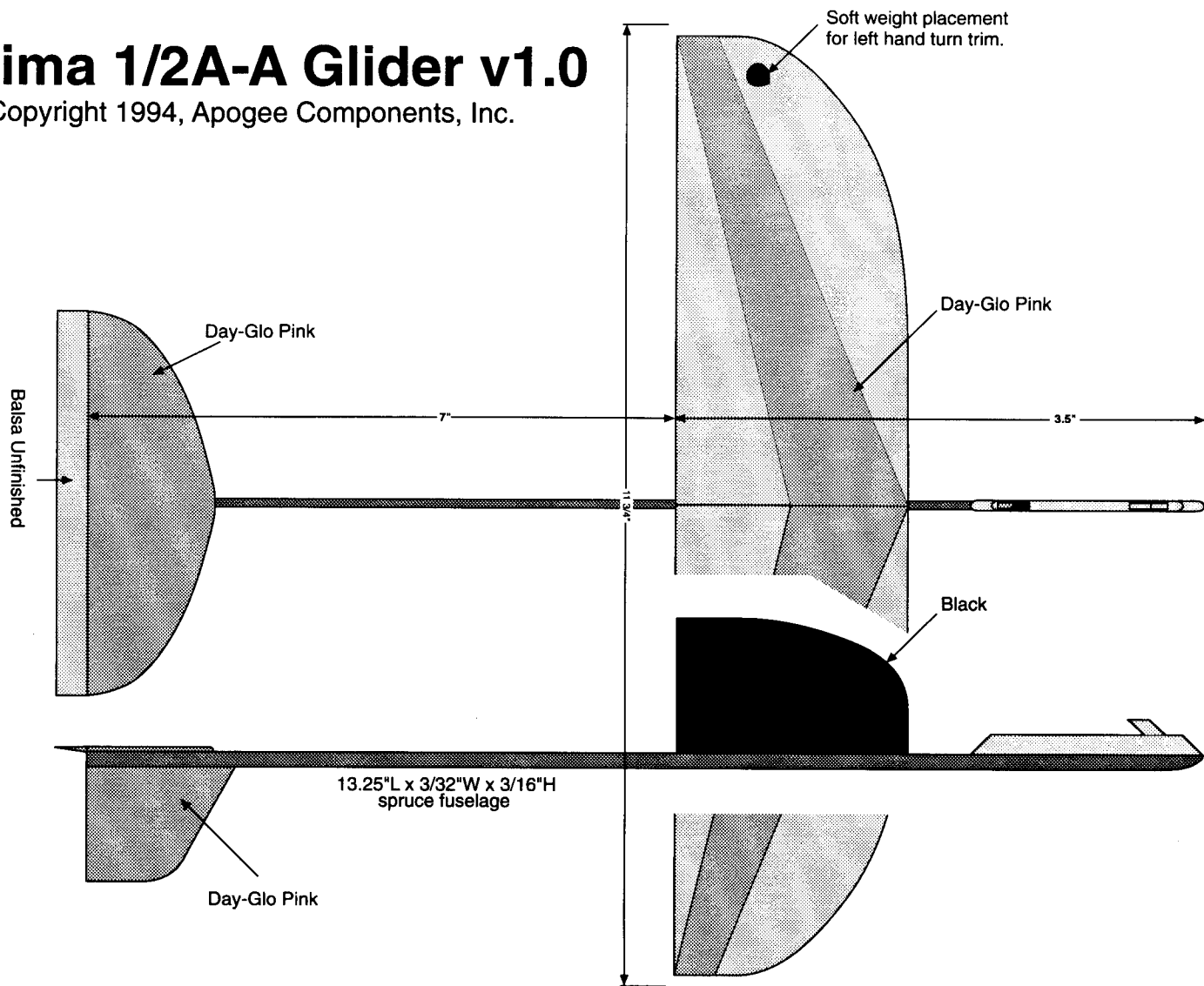

Sport/Competition

Rocket Boosted Glider Kit:

Maxima B/G Assembly Instructions, Copyright 1/23/94, A.C.I.

Skill Level: 3

Features:

Pre-Cut Contest Balsa, Molded "No Baron" Pod/Glider Hooks, Red Baron resistant pop-pod design.

Length: 13.25 inches. Wing Span: 11.75 in. Glider Weight: 12gms
Recommended 13mm Motors: Estes: 1/2A3-2T, A3-2T, A3-4T,*
(preferred delay)

Intro: The Maxima is the first boost glider kit to feature a simple, yet bulletproof pod attachment system that virtually eliminates the dreaded "Red Baron"! Built and trimmed properly, the Maxima boosts straight and can work the lightest air to the benefit of the competitor.

Assembly Tips:

Read these instructions before beginning assembly of your Maxima. To produce the best results, understand in advance what tools and techniques will be used in the construction of this kit.

CAUTION: You **must** be familiar with **Cyanoacrylate** adhesives (cyano'), before you begin construction. Use Cyano's only in well ventilated areas, and **avoid** breathing the fumes. Apogee recommends the use of a carpenter's wood glue construction of the Maxima if Cyano' is unavailable or inappropriate given the age of the modeler.

Parts and Supplies:

Apogee asks that you locate and identify the parts you received in your Maxima 1/2A-A kit, by checking the parts list below.

Maxima 1/2A-A Glider Parts:

- 1 - Balsa Wing blank - 3/16" thick
- 1 - Balsa Stabilizer - 1/20" thick
- 1 - Balsa Rudder - 1/20" thick
- 1 - Spruce Fuselage - 13.25 inches long
- 1 - piece of "soft weight" for trimming
- 2 - "No Baron" glider/pod hooks

Pod Parts:

- 1 - Yellow PP146 body tube
- 1 - 14mm Balsa nose cone
- 1 - White MT13175 motor tube
- 1 - Gray EB-13 motor block
- 1 - 1.5" LL-3 launch lug
- 1 - 12" KSL-100 shock line
- 1 - 1" x 8" Fluorescent red streamer
- 1 - 6mm Yellow plastic bead

In **addition** to the parts supplied in your Maxima kit, you will **need** the following tools and materials:

- Cyanoacrylate glue, FAST formulation (or yellow wood glue)
- Modeling knife with #11 blade
- **Flat** sanding block
- #60, #100, #220, and #400 sandpaper
- Fine line marker (Sanford Extra Fine Point)
- 3M Double-stick tape
- 12" ruler
- Wax paper - 4" x 6" piece
- SIG Lite-Cote or Pactra Aerogloss Clear dope (preferably SIG dope)
- 3/4 inch paint brush

Optional Tools and Materials:

- Cyanoacrylate accelerator
- Razor saw
- Colored magic markers (preferably Marks-A-Lot brand markers)

Some Construction Tips in Advance:

- When sanding balsa in this kit, please pay attention to the request grade of paper.
- When possible, sand wood with the grain to minimize gouging and deep scratches.
- Test fit parts together **before** final bonding. Joints like those formed by the wing dihedral are especially important to check and be sure they are flat, straight and fit tightly together.
- Take the time to be precise!

1) Spruce Fuselage Preparation:

A-Locate the 14-1/2 inch long spruce fuselage. This will form the "fuselage" of the glider. Use a sanding block and #100 grit paper to sand smooth the top, bottom and sides. Lightly sand to remove any "fuzz" from the edges.

2) Stabilizer and Rudder Preparation and Attachment:

A-Locate the stabilizer (stab') and rudder. Sanding with the grain, use the sanding block and #220 grit paper to sand both sides of each piece smooth.

B- Study Fig.1. Use #220 grit paper to sand smooth both sides of the stab' and rudder. When finished, continue with the #220 grit paper to round the leading edge of both pieces. Then use #220 grit wrapped around the sanding block to carefully taper the trailing edge of both pieces.

When sanding the trailing edge of the stab', be sure to make the edge thin and flexible.

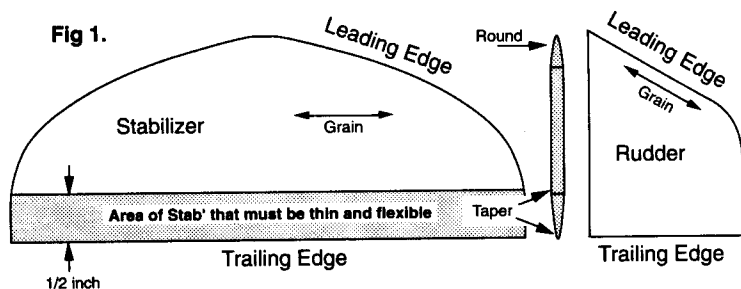

C- Study Fig.2. Locate a **fine-line** marker and a ruler. Lay the stab' inside the outline shown in Fig.2 and **center** it. Use the fine-line marker and ruler to draw lines across the stab' connecting A to A, B to B and C to C. Flip the stab' over, center it one more time and draw a line on the stab' connecting C to C a second time.

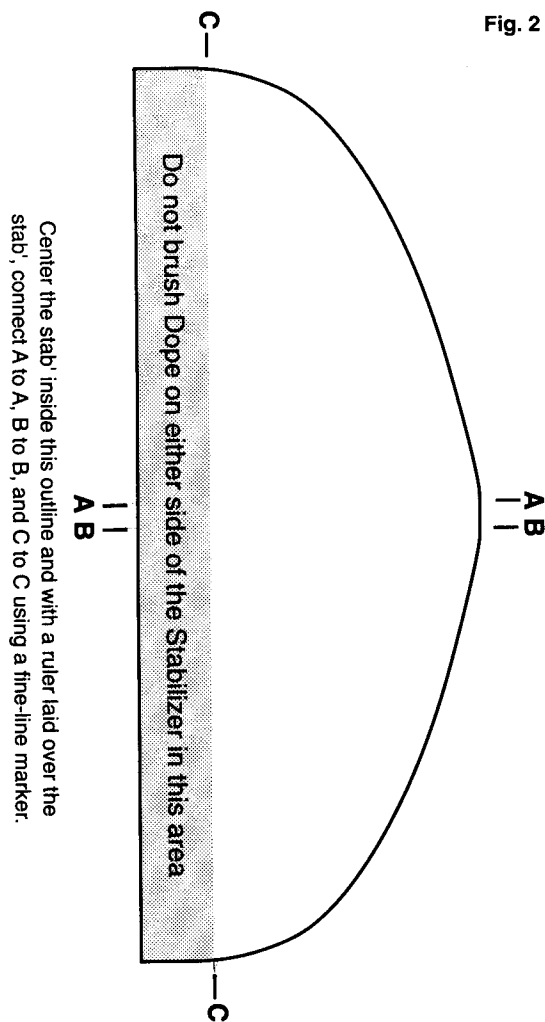

Fig. 2

D- Study Fig.3. Lay the stab' down on a flat surface with the two lines you just made in Step 2C, facing up. Pick up the fuselage and center either end between the two lines with the tip of the fuselage touching the line "C-C" that runs parallel to the trailing edge. This means that 1/2 inch of the stab' will hang off the end of the fuselage. Being sure that the fuselage is straight between the two lines, tack it in place with Fast Cyanoacrylate (cyano) cement.

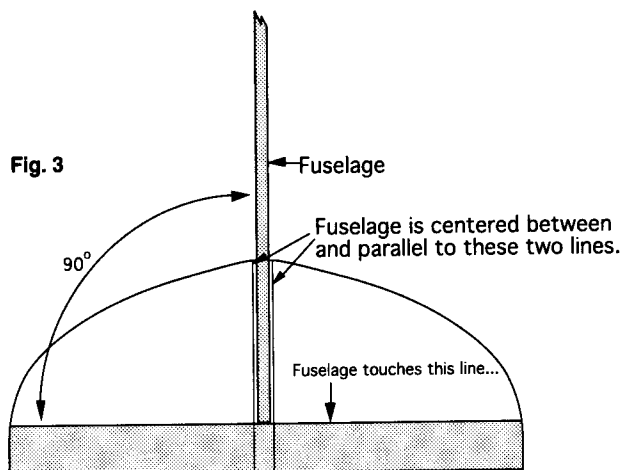

Fig. 3

E- Study Fig.4. Now position and align the rudder on the fuselage so that it is pointing straight ahead, perpendicular to the stab' and so the trailing edge is even with the end of the fuselage. Tack it in place with the Fast Cyano' cement. Now pick up the assembly and look at it from the rear. The stab' and rudder should form a perfect "T" and the rudder points **straight** ahead. If the parts were lightly tacked in place, then you should be able to break either piece loose if it is misaligned - and more accurately reattach it (them).

F- Once you are satisfied that the rudder and stab' are properly aligned to one another, **thoroughly** wick Fast Cyano' along the joints they create with the fuselage for added strength as shown in Fig. 4a.

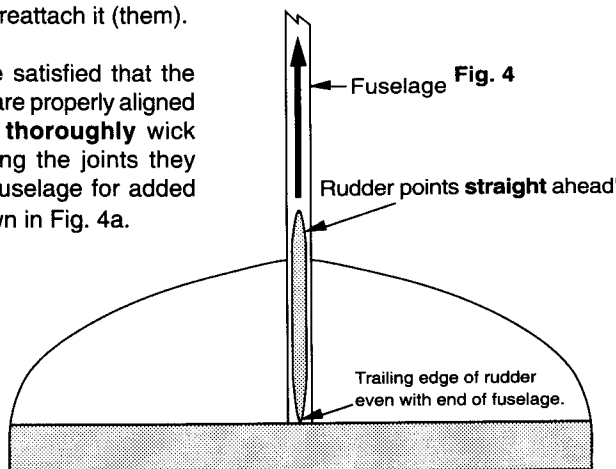
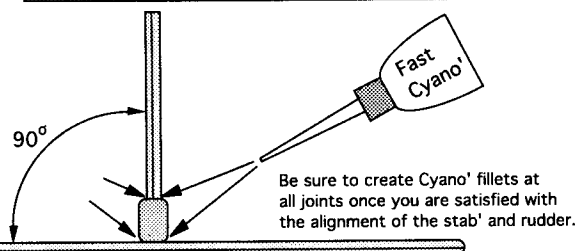

Fig. 4a



3) Wing Profiling and Assembly:

Take a good look at Fig.5. This is a leading edge to trailing edge cross-section of the wing's ideal airfoil profile. **Fig. 5:** Cross section of the desired airfoil. **This is the profile you desire.**



A- **NOTE:** Do all the following wing profiling and assembly **work on the flattest work surface you have.** To reduce the amount of time and effort needed to produce the wing's airfoil profile, the wing blank has already had **trailing edge** material partially removed (Fig.6). Use a sanding block and #100 and then #220

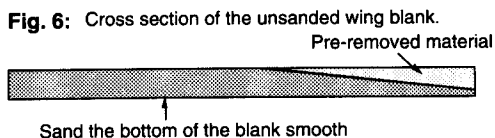

grit paper to sand the bottom of the wing blank smooth. Then lay the wing inside the **Maxima B full size wing outline** and make sure the wing is the correct shape. Use the sanding block to make any adjustments.

B- Refer to Fig.7 & 7a. Wrap the sanding block with #100 grit sandpaper. Working right next to the edge of your work surface (so that you can see the trailing edge of the wing blank) begin sanding the beveled area of the wing with the grain. You want to smooth the surface **and** round the blank towards the trailing edge. **Do not** sand the trailing edge sharp; leave a 1/32 inch wide blunt edge visible.

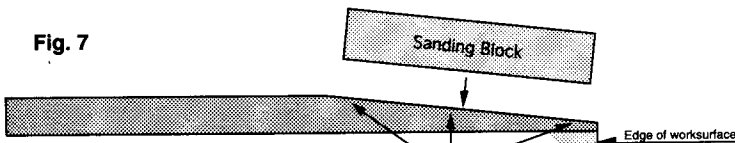
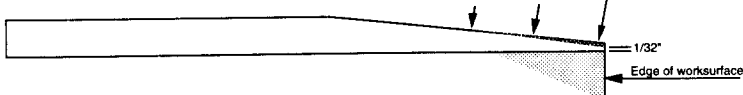

Fig. 7

1- Sand the trailing edge surface smooth then...

Fig. 7a

2- Remove balsa in this area as you round the blank towards the trailing edge



C- Locate the **Maxima B Airfoil High Point Template** and a **fine-line** marker. Carefully cut out the template, center it on the wing. Be sure that the template's trailing edge is flush with the wing's trailing edge. Trace along the front edge of the template with the marker so that you leave a curving line across the top of the wing blank (Fig.8).

NOTE: The airfoil high point is where the upward curve from the leading edge ends and the downward curve of the trailing edge begins.

Fig. 8

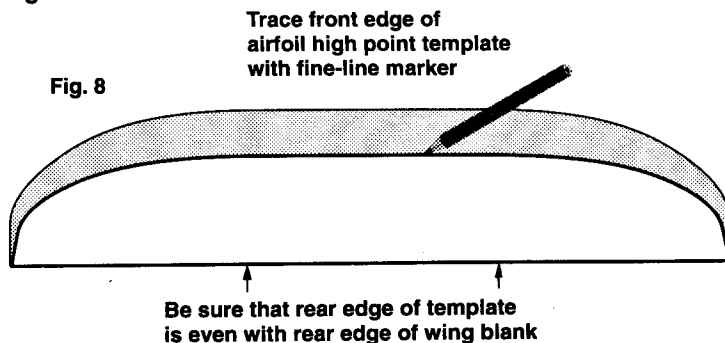

Before you move on to the next step, please keep in mind the following points:

1- In the process of airfoiling the wing blank you may sand away portions of the Airfoil High Point line you just traced on the wing blank- especially near the wing tips. No problem; simply retrace the Airfoil High Point Template as many times as is needed. Just be sure you know where the Airfoil High Point is.

2- Also, all the Airfoil High Point denotes is where the airfoil is thickest at any point along the span of the wing. It doesn't mean that the wing is supposed to **remain the thickness of the wing root along this line**, all the way out to the tip. As a matter of fact, as you airfoil the wing, don't hesitate to sand the wing thinner as you work towards the tips of the wing - it's necessary for the tips to be thinner so the airfoil can be the proper shape!

Now for profiling the leading edge.

D- What is easiest is to begin by beveling the area between the high point and the leading edge first (Fig's. 9 & 9a). This will remove a lot of unnecessary wood. Because the leading edge and the high point converge as you work closer to the wing tip, the bevel angle will change. Take your time and work slowly.

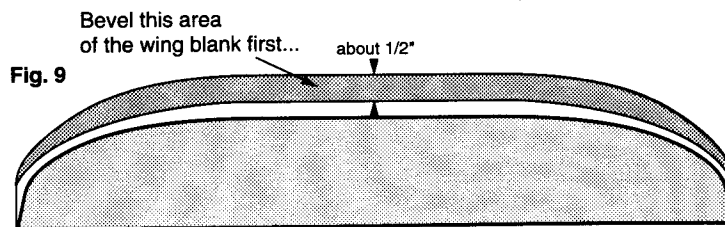

Fig. 9

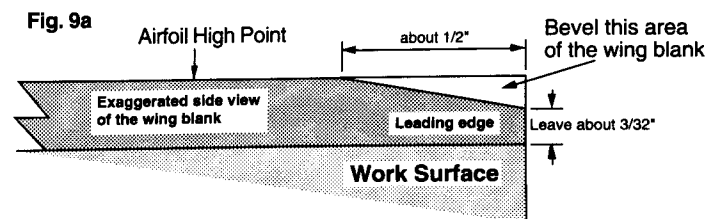
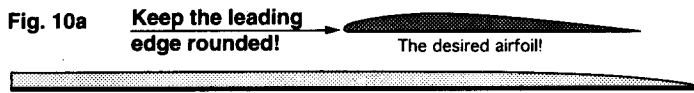
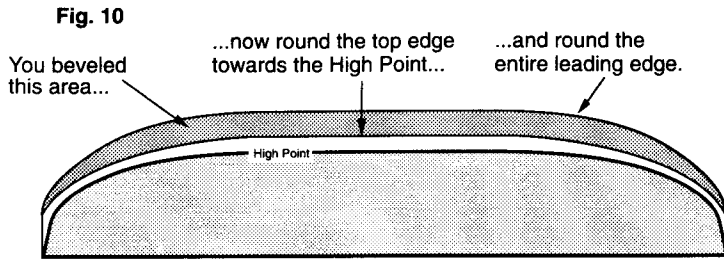

Fig. 9a

E- After beveling the edge, round the top edge towards the high point and round the entire leading edge as indicated in Fig.10 (**keep in kind the desired shape**). Use your sanding block with 100 grit sandpaper and continue to work **slowly!** As shown in Fig.10 & 10a, you want a **rounded leading edge** and a wing that becomes progressively thinner near the tip.



The right half of the wing viewed from the trailing edge, shows how the wing blank gets thinner towards the tip.

After you are satisfied that you have the overall shape of the wing the way you want it, switch your sandpaper to #220 grit and then to #400 grit for final overall smoothing of the wing. As you put the finishing touches on the wing, should you encounter any deep scratches anywhere, be careful not to over sand in an attempt to remove them.

F- Center your airfoiled wing blank on the Maxima B full-size wing outline. Use a ruler and a fine line marker to draw a line across the wing's upper surface, connecting "A to A".

G- Locate either a razor saw or a #11 modeling knife with a sharp (preferably new) blade. Using the ruler as a guide, **carefully** cut on the line to separate the wing into two pieces (Fig.11). If you are using a knife - **go slowly** -make numerous light passes as you cut down through the wing. You don't want to tear or crush the balsa.

H- With the wing now cut apart, the root edges of each half need to be beveled so that when they are glued back together, a "vee" in the wing is formed. (This vee is the wing's **dihedral**, and is very important to proper performance.) Study Fig.11a for the setup necessary to beveling the root edge of each wing half. Working again at the edge of your work surface, elevate the tip of one wing **1 3/4 inches**. Wrap the sanding block wrapped with #100 grit paper. Keeping the sanding block square (90 degrees) to the edge of the work surface, sand the root edge until the entire root edge is angled. Perform the same procedure on the other wing half.

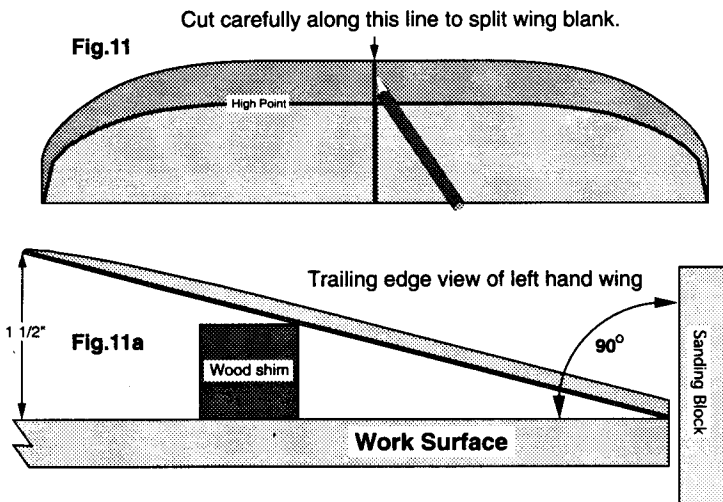

I- Now the two wing halves need to be glued back together. Study Fig.12 to see what the gluing setup looks like. Before gluing, be sure to double check the root edge fit of the two wing-halves to one another. Do this by holding a wing in each hand, sliding the root edges together on your work surface and then tilting the wing tips up. As the joint comes to a close, there should be no gaps visible. After checking the root-edge joint, set the wings **up on a piece of wax paper** as shown in Fig.12 and apply **Fast Cyanoacrylate (Cyano')** cement along the top of the joint. Let dry. Make a second application of Cyano' to the joint - spreading it well onto both sides of the joint (Fig.12a)- and let dry.

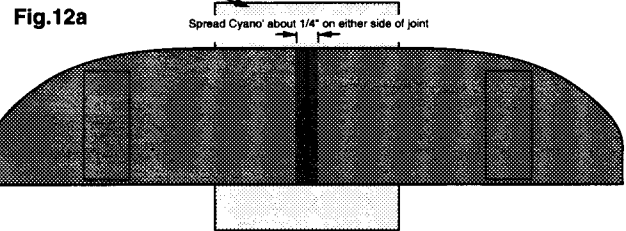
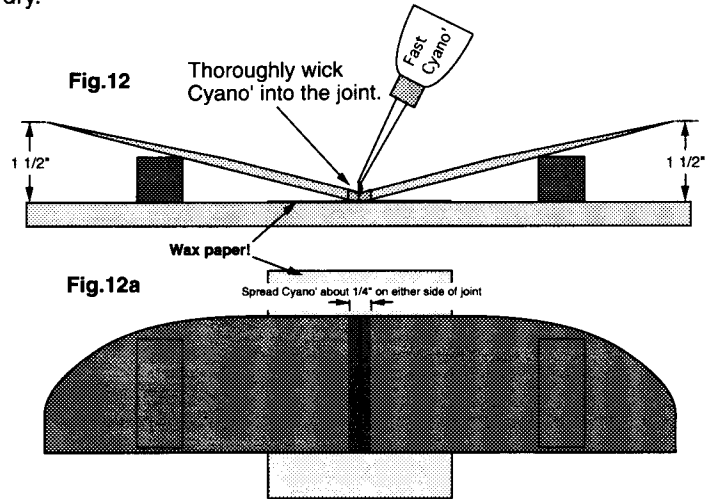

4) Wing and Fuselage Assembly:

A- Locate the ruler, the fine-line marker, and the fuselage/tail feather assembly. From the forward tip of the fuselage, measure back **3 1/2"** and make a mark on the **top** of the fuselage. (Fig.13)

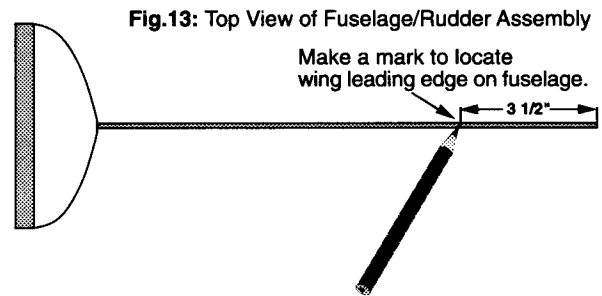

B- Time to bond the wing to the fuselage. This must be done with as much accuracy as possible! Study Fig's.14 & 14a for help in visualizing proper alignment of the wing before bonding it to the fuselage. The important points are:

- 1-The leading edge is touching the mark you made on the top of the fuselage...
- 2-Trailing edge is 90 degrees to the fuselage...
- 3-The wings are level in relation to the stab'.

Take your time to get the wing on right!

When you have the wing properly aligned on the fuselage, **tack** it in place with a small drop of Cyano'. Now carefully reexamine your alignment one more time; if you detect any misalignment, pop the wing off the fuselage, realign it, and again re-tack the wing. Once you are

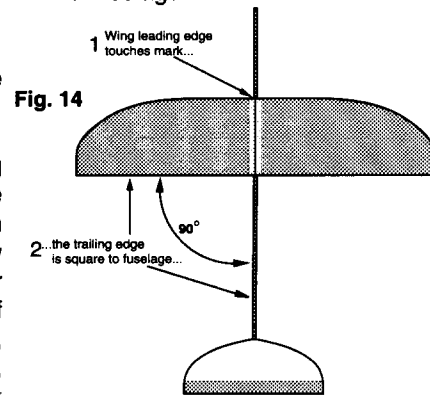

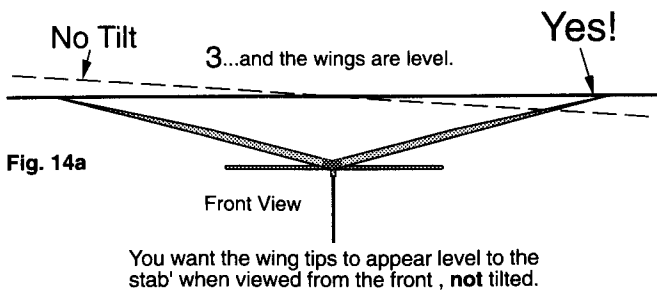

satisfied the wing is tacked on correctly, wick Cyano' into the wing/fuselage joint on both sides of the fuselage. After the first application of Cyano' has dried, be sure to make a second application of Cyano' to the wing/fuselage joints so that a small fillet is formed. CONGRATULATIONS! All the hard work is now behind you.

5) Pop-Pod Assembly:

A- Locate a paint brush and a container of clear dope. Apply a coat of clear dope to the balsa nose cone and set it aside to dry.

B- Locate the 12 inch piece of Kevlar and the gray EB-18 motor block. Tie one end of the Kevlar to the motor block with the "slip" knot shown in Fig. 15.

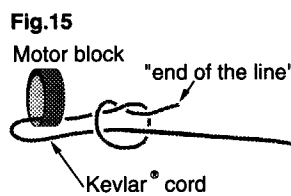

C- Locate the white, 2 3/4 inch long motor tube, a ruler, and a fine-line marker. Measure and make a mark on the motor tube, 1/4 inch from one end as shown in Fig. 16.

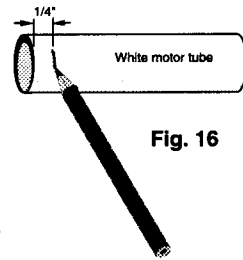

D- **Opposite** the end you just marked, insert the motor block/Kevlar cord assembly flush with the end of the white motor tube as shown in Fig. 17. Use Cyano' to bond the motor block into the motor tube. Once the Cyano' is dry, feed the Kevlar back through the motor tube so it is hanging out the marked end as shown in Fig. 17a.

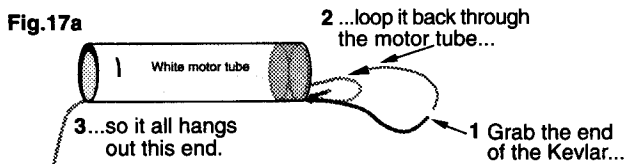
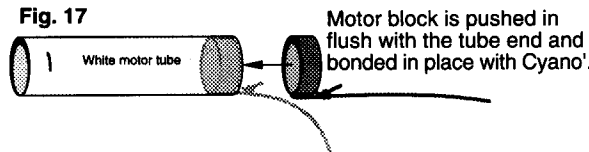

E- Locate the Yellow Pop-pod tube and note that a black line has been drawn on the outside at one end. Insert the white motor tube, **motor block first**, into the black line marked end of the Pop-pod tube **stopping** at the 1/4 inch mark as shown in Fig. 18.

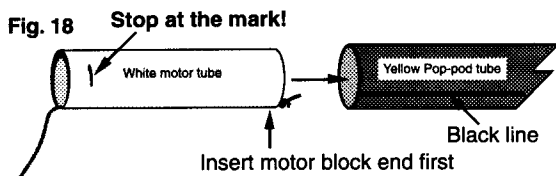

F- Now feed the Kevlar cord back through the pop-pod tube assembly (so it all hangs out the front of the yellow tube) and wick fast Cyano' into the joint formed by the two tubes (Fig.19). Set aside to dry.

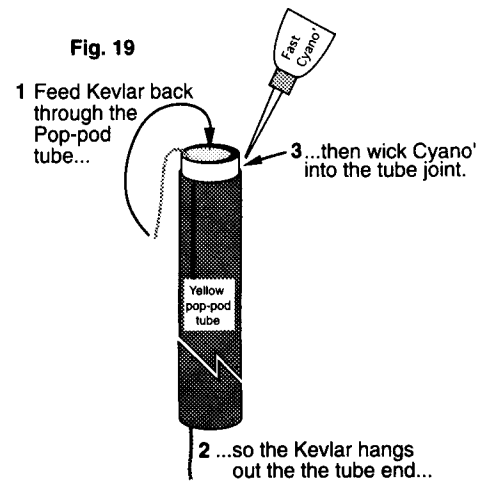

G- Apply a second coat of clear dope to the balsa nose cone and set aside to dry.

H- Locate the yellow plastic bead. Slip the yellow bead onto the Kevlar cord. Tie a single overhand knot in the free end of the Kevlar and lock the knot with a small drop of Cyano' as shown in (Fig.20).

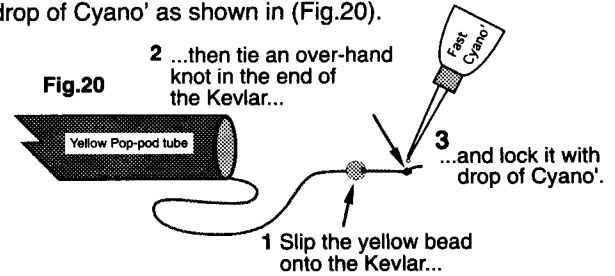

I- Making sure the nose cone is dry, sand the nose cone smooth with #400 grit paper.

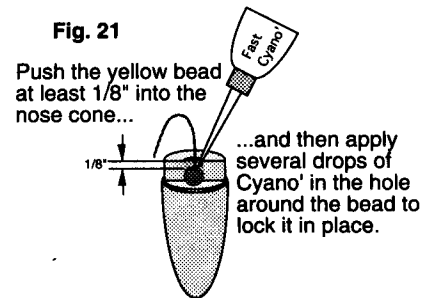

J- Slide the yellow bead down to the knot in the Kevlar and proceed to press the bead at least 1/8th of an inch into the hole in the bottom of the nose cone. Once the bead is in place, apply several drops of Cyano' into the hole around the bead to bond the bead in place (Fig.21).

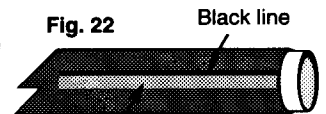

K- Locate one of the two molded hooks, the pop-pod assembly and a piece of #220 grit sandpaper. Use the sandpaper to roughen the area **alongside** the black line on the pop-pod tube (Fig 22). **Paying attention** to the hooks orientation as shown in Fig.23, hold the hook on the roughened area so that it points **straight** ahead, and bond it in place by applying Cyano' to both sides of the hook/tube joint. Be sure to make a second application to both sides of the hook after the first has dried.

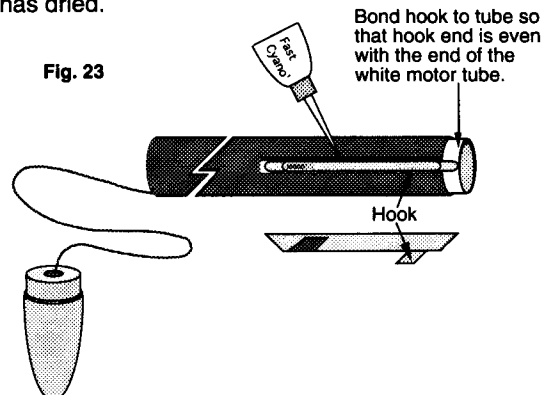

L- Locate the 1 1/2 inch long piece of launch lug. Lay it in the hook/ tube joint as shown in Fig. 24 and bond it in place with Cyano'.

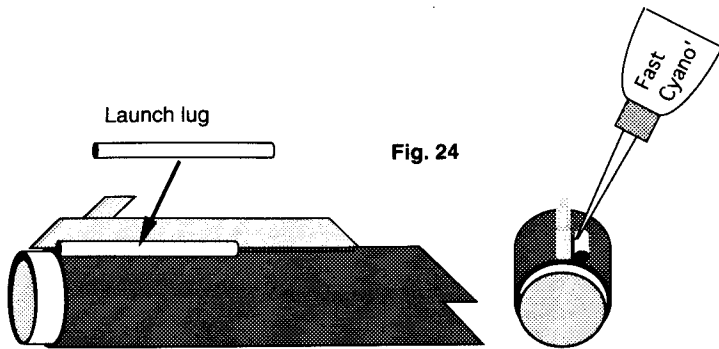

Now at a point about 1 1/2 inches from the end of the pop-pod tube, lay the Kevlar cord in the crease next to the double-face tape and fold the streamer back over onto itself. Press firmly on the folded corner to capturing the Kevlar (Fig.26).

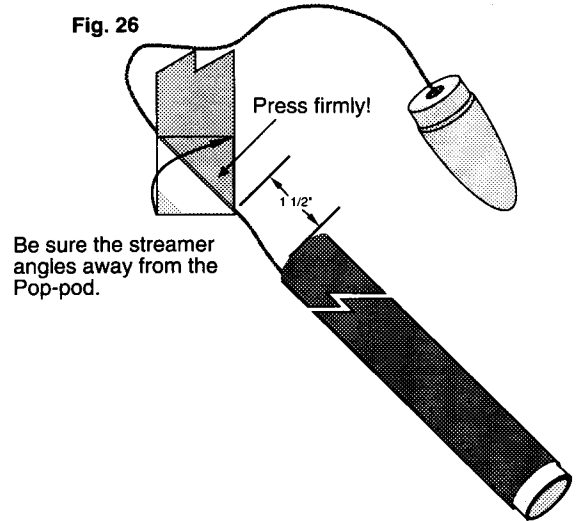

M- Locate the 8 inch piece of Fluorescent Streamer material and your double-face tape. Fold one corner of the streamer over and apply a strip of tape to the streamer as shown in Fig's 25 & 25a.

Fig. 25

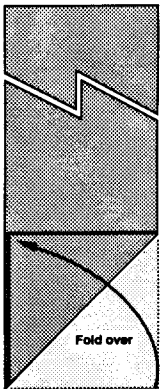
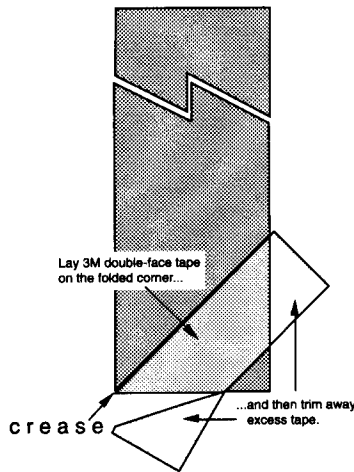

Fig. 25a



N- Locate the second molded hook. Referring to Fig.27, correctly orient this hook at the front end of the glider's fuselage and carefully bond the hook to the fuselage so that it **points straight ahead**. Use your sanding block and #100 grit paper to round the front of the fuselage below the hook.

Finishing the Glider:

Fig. 27

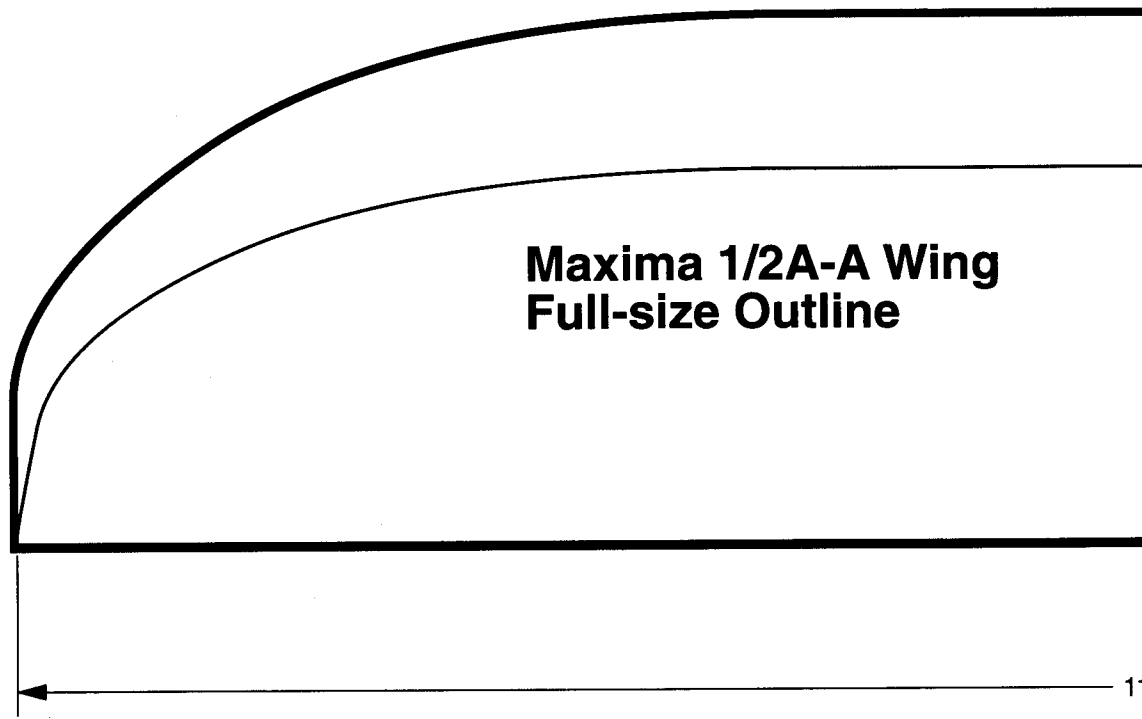
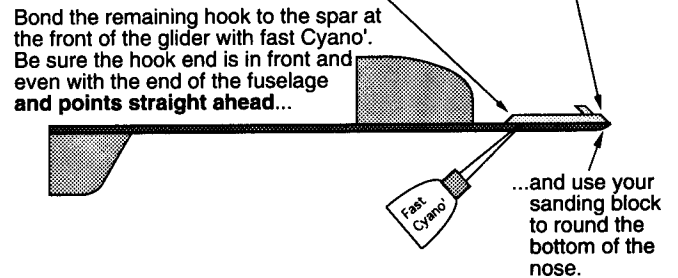

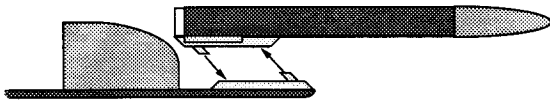

It's just, this, easy!

Your Maxima's wing (and tail feathers) will be more durable and perform best if you apply a clear dope finish. Apogee recommends that you use SIG Lite-Cote dope brushed on with the grain. Apogee prefers Lite-Cote dope as it is far less likely to warp the wood after application, than other clear dopes. Two coats of clear dope is sufficient. You need not sand between coats. Sand lightly after the final coat with #400 grit sandpaper until the surfaces are smooth.

WARNING: DO NOT apply any dope to the trailing edge area of the stab' as indicated back in Fig.2. This part of the stab' needs to remain flexible for trimming purposes.

Glider Coloration:

In order to more easily see your Maxima during flight, and to help in finding it once it has landed, it is recommended that you apply some color. To keep weight to a minimum, a favorite trick is to use permanent markers for they add virtually no additional weight to the glider. Apogee **strongly** recommends that you try to find a Marks-A-Lot brand **fluorescent** marker set. This is a set of three "hot" colors (pink, orange, and green) and black, and should be available at most art or office supply stores. Refer to the full size illustration of the Maxima for color use. If fluorescent color markers cannot be found, then as bright a red as you can find should be used. The nice thing about using markers to color gliders, is that you can be very "free-form" about your color pattern. The only guidelines to follow are: dark on the bottom of the wing and bright just about anywhere else you like.

Boost and Glide Trim Theory:

The Maxima B/G has been designed to be trimmed as though it were a free-flight hand-launched glider. The wing and stab' have been attached so that their bottoms are parallel to one another. This is known as a "zero-zero" configuration.

Now, a glider built "zero-zero" will boost the straightest and coast the straightest after motor burn-out. But, if a "zero-zero" built glider

should get nose down during flight (which it might during pop-pod separation and transition to glide) it lacks any "restoring force" to help it pull up and return to level flight. (A lack of restoring force is what causes a glider to plunge to the ground or "death dive" whenever the nose gets pointed down sufficiently.)

Why then has Apogee had you build your Maxima in a zero-zero configuration? Because if the entire stab' is attached to the fuselage where the trailing edge is higher than the leading edge (this is known as "negative incidence") then chances are the glider will loop strongly onto its back at motor burn-out. It might even begin looping onto its back during boost if the entire stab' is angled too steeply. With the trailing edge of the Maxima's stab' sanded thin and flexible, only that portion of the stab' is warped up. And the trailing edge is warped up only as much as is needed to produce the best "balance" between sufficient restoring force and the degree to which the glider will arc onto its back at motor burn-out. The best way to find that balance is by test flying the glider with motors smaller than the maximum recommended. In the case of the Maxima B, Apogee recommends that trim test flights be made with A8-3 motors.

Initial Trim:

For starters, take your Maxima, the supplied "soft weight", and a piece of masking tape to a grassy (or at least smooth) area. Even with the wing and stab' built "zero-zero", the glider if tossed lightly (and low to the ground) will stall. So start by trimming your Maxima to glide when tossed from shoulder height and level with the ground.

Once gliding, it is time to warp the stab' trailing edge up - but only slightly - 1/64" will be plenty. To warp the trailing edge, moisten your thumbs and forefingers and grasping the stab' at the center of the trailing edge, alternately stroke the stab' towards each tip while bending the trailing edge upwards at the same time. (The moisture will further soften the wood, making it more easily warped.)

You will know if you have achieved some desired "negative incidence" because if you re-toss your glider - **it will now stall**. Stop warping the stab' and go back to adding nose weight so that once again your Maxima will glide. Once a glide has again been achieved, the only thing left to do is add a small dot of the "soft weight" to the left wing-tip. (If the "soft-weight" does not wish to stick to the wing, place a small square of masking tape at the wing tip and the "soft weight" will stick

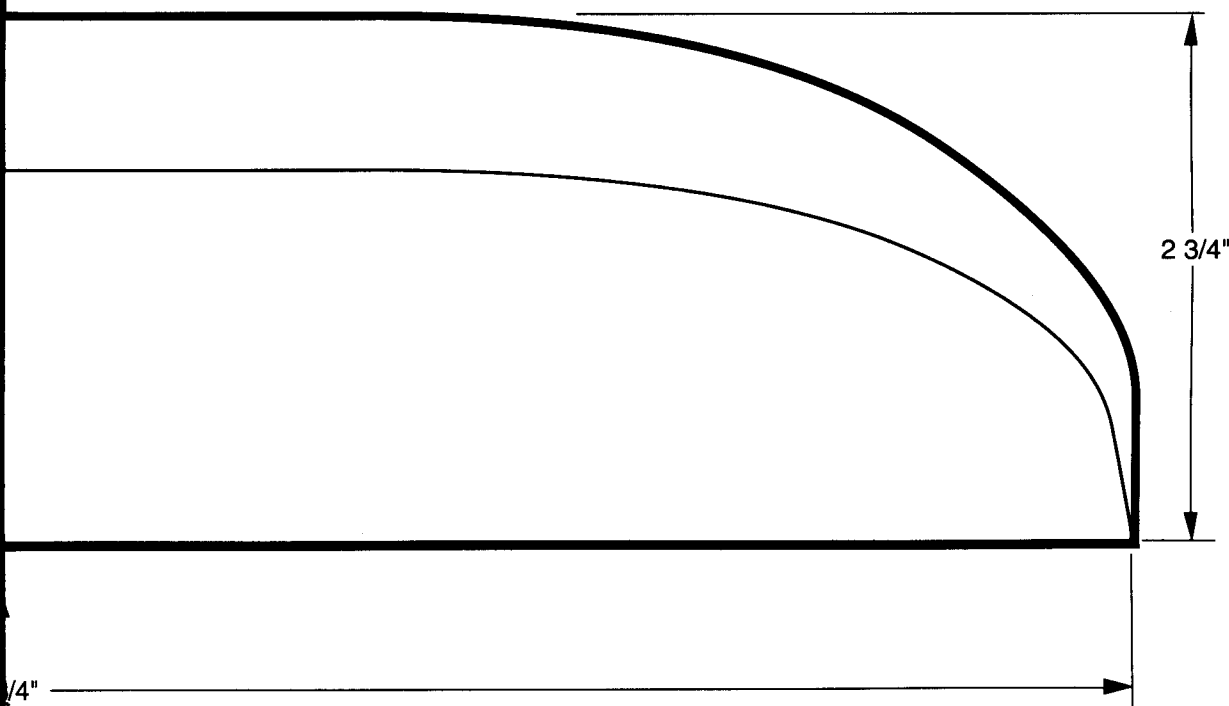

TODAY
1983

S M T W T F S

JANUARY

1 2
3 4 5 6 7 8 9
10 11 12 13 14 15 16
17 18 19 20 21 22 23
24 25 26 27 28 29 30
31

FEBRUARY

1 2 3 4 5 6
7 8 9 10 11 12 13
14 15 16 17 18 19 20
21 22 23 24 25 26 27
28

MARCH

1 2 3 4 5 6
7 8 9 10 11 12 13
14 15 16 17 18 19 20
21 22 23 24 25 26 27
28 29 30 31

APRIL

1 2 3
4 5 6 7 8 9 10
11 12 13 14 15 16 17
18 19 20 21 22 23 24
25 26 27 28 29 30

MAY

1 2 3
4 5 6 7 8
9 10 11 12 13 14 15
16 17 18 19 20 21 22
23 24 25 26 27 28 29
30 31

JUNE

1 2 3 4 5
6 7 8 9 10 11 12
13 14 15 16 17 18 19
20 21 22 23 24 25 26
27 28 29 30

JULY

1 2 3
4 5 6 7 8 9 10
11 12 13 14 15 16 17
18 19 20 21 22 23 24
25 26 27 28 29 30 31

AUGUST

1 2 3 4 5 6 7
8 9 10 11 12 13 14
15 16 17 18 19 20 21
22 23 24 25 26 27 28
29 30 31

SEPTEMBER

1 2 3 4
5 6 7 8 9 10 11
12 13 14 15 16 17 18
19 20 21 22 23 24 25
26 27 28 29 30

OCTOBER

1 2
3 4 5 6 7 8 9
10 11 12 13 14 15 16
17 18 19 20 21 22 23
24 25 26 27 28 29 30
31

NOVEMBER

1 2 3 4 5 6 7
8 9 10 11 12 13
14 15 16 17 18 19 20
21 22 23 24 25 26 27
28 29 30

DECEMBER

1 2 3 4
5 6 7 8 9 10 11
12 13 14 15 16 17 18
19 20 21 22 23 24 25
26 27 28 29 30 31

B203

Maxima 1/2A-A Airfoil
High Point Template

Cut out along this line

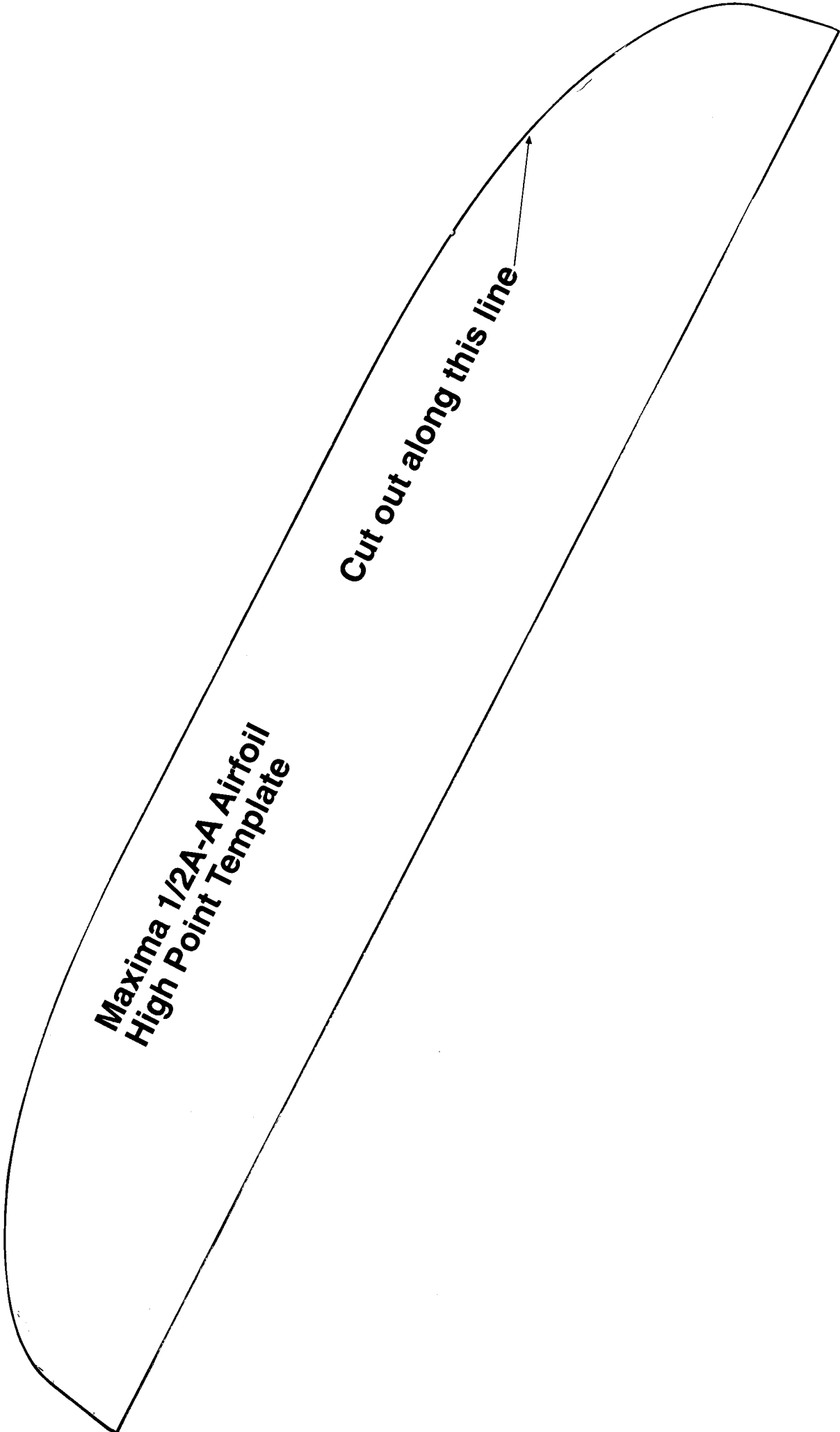

TODAY
1983

S M T W T F S
JANUARY

1 2
3 4 5 6 7 8 9
10 11 12 13 14 15 16
17 18 19 20 21 22 23
24 25 26 27 28 29 30
31

FEBRUARY

1 2 3 4 5 6
7 8 9 10 11 12 13
14 15 16 17 18 19 20
21 22 23 24 25 26 27
28

MARCH

1 2 3 4 5 6
7 8 9 10 11 12 13
14 15 16 17 18 19 20
21 22 23 24 25 26 27
28 29 30 31

APRIL

1 2 3
4 5 6 7 8 9 10
11 12 13 14 15 16 17
18 19 20 21 22 23 24
25 26 27 28 29 30

MAY

1 2 3 4 5 6 7 8
9 10 11 12 13 14 15
16 17 18 19 20 21 22
23 24 25 26 27 28 29
30 31

JUNE

1 2 3 4 5
6 7 8 9 10 11 12
13 14 15 16 17 18 19
20 21 22 23 24 25 26
27 28 29 30

JULY

1 2 3
4 5 6 7 8 9 10
11 12 13 14 15 16 17
18 19 20 21 22 23 24
25 26 27 28 29 30 31

AUGUST

1 2 3 4 5 6 7
8 9 10 11 12 13 14
15 16 17 18 19 20 21
22 23 24 25 26 27 28
29 30 31

SEPTEMBER

1 2 3 4
5 6 7 8 9 10 11
12 13 14 15 16 17 18
19 20 21 22 23 24 25
26 27 28 29 30

OCTOBER

Maxima 1/2 A-A Stabilizer

1/20" thick balsa

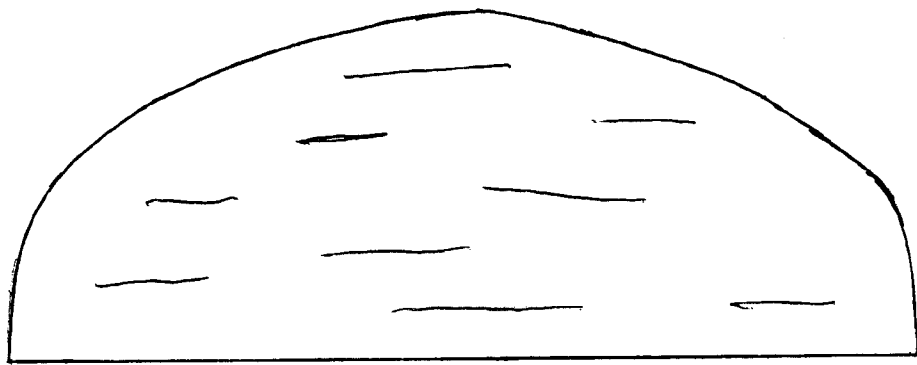

Maxima 1/2 A-A Rudder

1/20" thick balsa

