

S3. Parachute Folding Technique. Russian version (Korjapin - Mitiuriev).

I have been using this particular parachute folding technique for at least 12 years, and reasonably successful. With transition to the given techniques there were no failure of parachute deployment (about several hundreds of flights during 12 years). The technique has been “borrowed” from Alexey Korjapin (currently he is Russian team manager/coach, and one of the most decorated Russian spacemodeller – 3 time World Champion (individual) – all in S1.

The success of implementation of this particular technique is to be meticulous in details, the other simple technique “hold the chute’s pole - pull shrouds - put them on top” will not provide folding repeatability for different chutes and repeatability for folding of each section of each chute.

The given description is not Koriapin’s original version, but is very close one - of this child’s interpretation/version. So there are some absolutely insignificant deviations from original Korjapin’s Folding method.

Chute’s deployment delay is a minimal, without altitude loss. And chutes are deploying reliable with very low ram air speed.

The technique was applied to chutes made out of 3-5 microns (0.1-0.2 mil) mylar (polyethylene terephthalate).

A. PARACHUTE PREPARATION BEFORE FOLDING.

Pre-fold parachute in more clean not disturb and better controlled environment. You will save precious time during competition on the field; and also you will perform such critical operation under better condition.

Surface for folding should be prepared – clean and covered with paper / newspaper.

Parachute should be lay out with shroud line stickers on the external side of canopy. This is done intentionally to reduce probability of parachute sections pasting by adhesive coming from under the stickers.

NOTE: Attachment’s illustrations are conventionalized with 8 shrouds. Dimensions in mm

Draw. 1 : Shroud lines should be impregnated/rubbed with talc prior to parachute folding. Take a pinch of talc in one hand, hold shrouds end line in another hand, pull these shrouds through talc from the top to the shrouds connection to canopy. Disperse talc into both sides of canopy.

Draw. 2 : Lay out the canopy on a table with shroud line stickers upwards and cover each sticker with talc. Slightly “trample” the surface of the canopy by your palms. Take the shrouds end line and shake of excessive talc from the canopy’s surface.

B. PARACHUTE FOLDING.

You will need 3 simple tools:

- Clamping weight – 2 metal (steel or alum) plates (approximately 40 x 80 x 1 mm (Position 1, Draw 5).
- The wooden stick-clamp-clip, oblique approximately under 45 degrees and rounded on the edges (**Position 2, Draw 6**).

Lay out the canopy on a table with shroud line stickers upwards again. And fold the canopy double the way, that shroud line sticker edge will distant from canopy bend approximately at 3...5 mm (see **Draw. 3**) (in order to avoid bending/un-sticking the shroud line sticker).

Draw. 4: Fix the fold, slightly pressing down with finger along the fold.

Draw. 5: Put Plate 1 onto the bend.

Draw. 6, 7, 8: Hold the top of the canopy by the Stick 2, drag the second shroud line and put it on top of the first one (**Draw. 6, 7, 8**).

Thus the second bend will be situated on top of the 1st bend. Pay attention to the formed and hidden by the top layer bend "at the left". It should be straight and has no scuffing.

Draw. 9: Shift the pressing Plate 1 on top of the folded part of the canopy.

Draw. 10: Fix the "right" visible and "left" hidden bends, slightly pressing down with finger along the fold.

Draw. 11: Shift the pressing Plate 1 onto the edge of the canopy.

Repeat operations, presented on the **Drawings 6-11** until all shroud lines will be on top of each other. Canopy is folded into sector – **Draw. 12**.

NOTE: It will be much easier to fold parachute second, third (and so on) time. The bends/folds will "remember" their location and will stack much easier, and that will help you to fold. Therefore it is very important to fold fresh-just-made-virgin parachute **ESPECIALLY ACCURATELY** for the first time!

Draw. 13: Stretch the shroud lines and place them in the middle of the formed sector.

Draw. 14: Place the pressing Plate 1 on top of the shroud lines at the distance approximately 1/3 ... 1/4 R from the top of the formed sector (R - radius of the parachute).

Draw. 15: Make a 180° turn of the shroud lines, spreading them on top of the first layer.

Draw. 16: Place second pressing Plate 1 on top of the shroud lines at the distance of 2-3 cm from the edge of the sector.

Draw. 17: Make again a 180° turn of the shroud lines, spreading them on top of the previous layer.

Draw. 18: Shift the first Plate 1, holding shrouds lines at the top of the sector, from under the shrouds lines on top of them.

Repeat the operations presented on **Draw. 15 – 18** until whole length of the shroud lines will lay down the top of the canopy's sector. Thus the free end of the shroud lines shall extend beyond the edge of the sector at about 5 ... 10 cm (2...4 inch) (or at the distance corresponding to your model design).

Draw. 19: Fold the formed sector double or into 3 sections (2 bends) or 4 sections (3 bends) – depending on diameter of your parachute and length of the parachute compartment of the model. Thus, the sector should be fan-folded (as letter Z in case of 2 bends) in case of 2 or 3 bends.

Draw. 20: Check, that "springing" loops of the shroud lines, located between the bottom and top layer(s) of the folded sector, did not extend beyond the top bends/layers of the sector in order to prevent shroud lines loops catching onto sectors folds.

Draw. 21 – 24: Fold formed folding lengthways by two (or more – depending on sector width) bends.

The formed folding can be attached to the model,

Or, as it was recommended above - preliminary fold the parachute in accordance with sequences presented on **Draw 1** through **Draw. 20** inclusive. Place the folding into specially prepared pocket made out of polyethylene / newspaper / magazine, etc. Preliminary folded chute can be taken out of this pocket, with the following folding completion per operations of the **Drawings 20 – 24**, and then parachute can be attached to a model.

Attachment: Illustrations “Parachute Folding Technique”.

Illustrations for material “Parachute Folding Technique”.

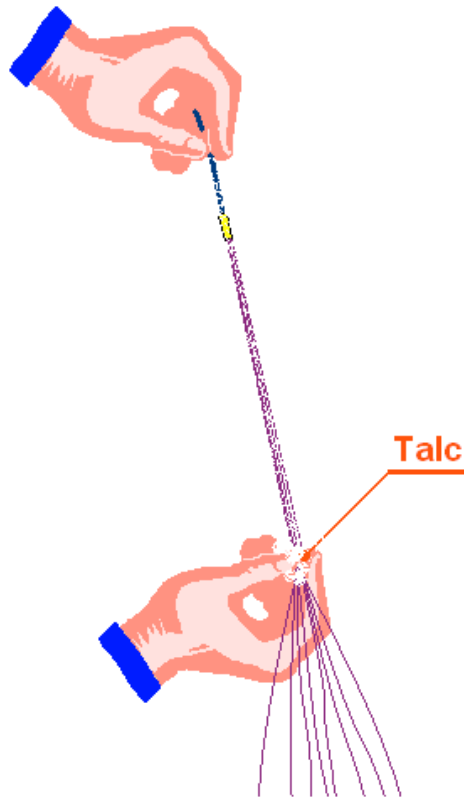

Draw. 1

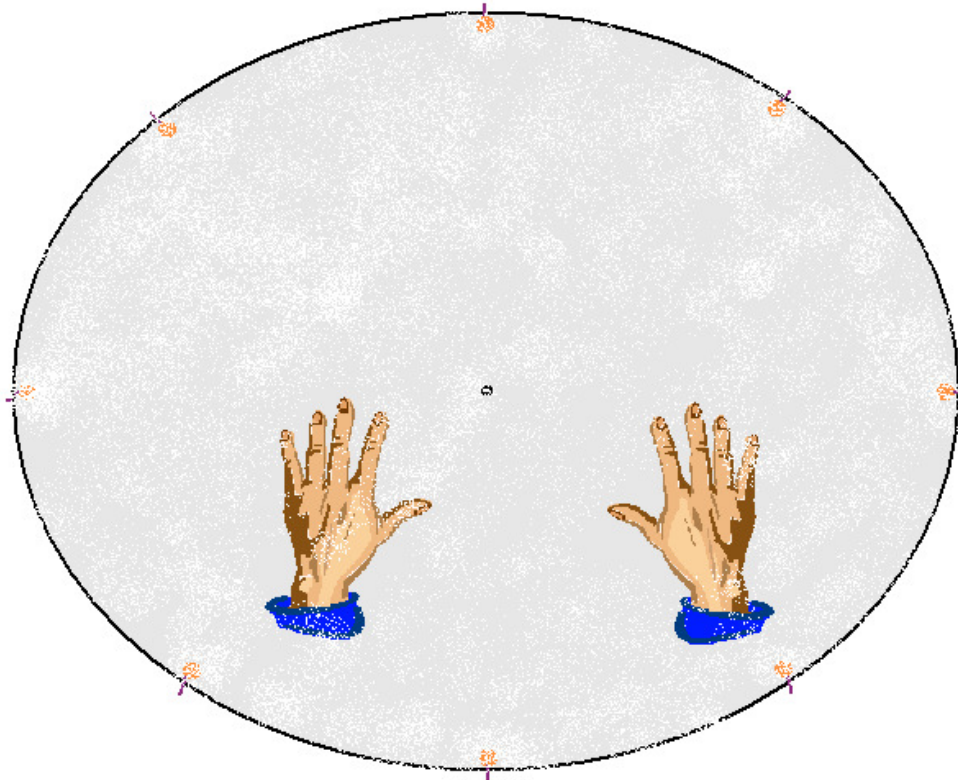

Draw. 2

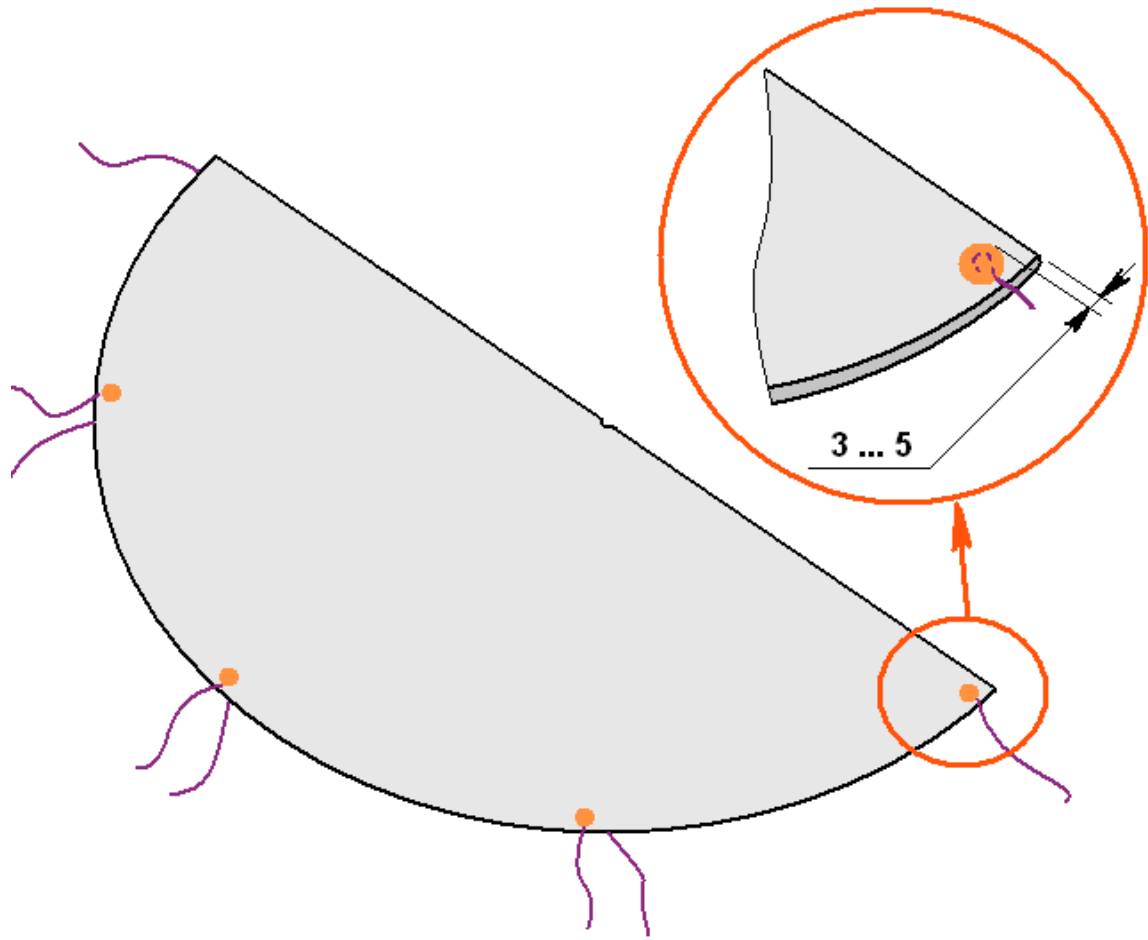

Draw. 3

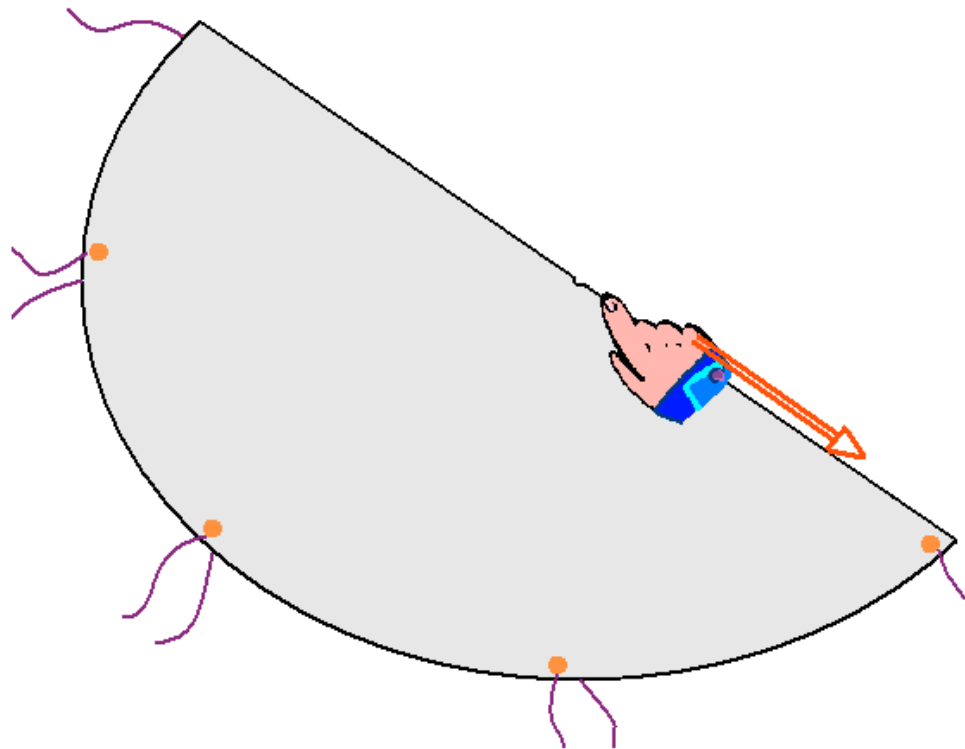

Draw. 4

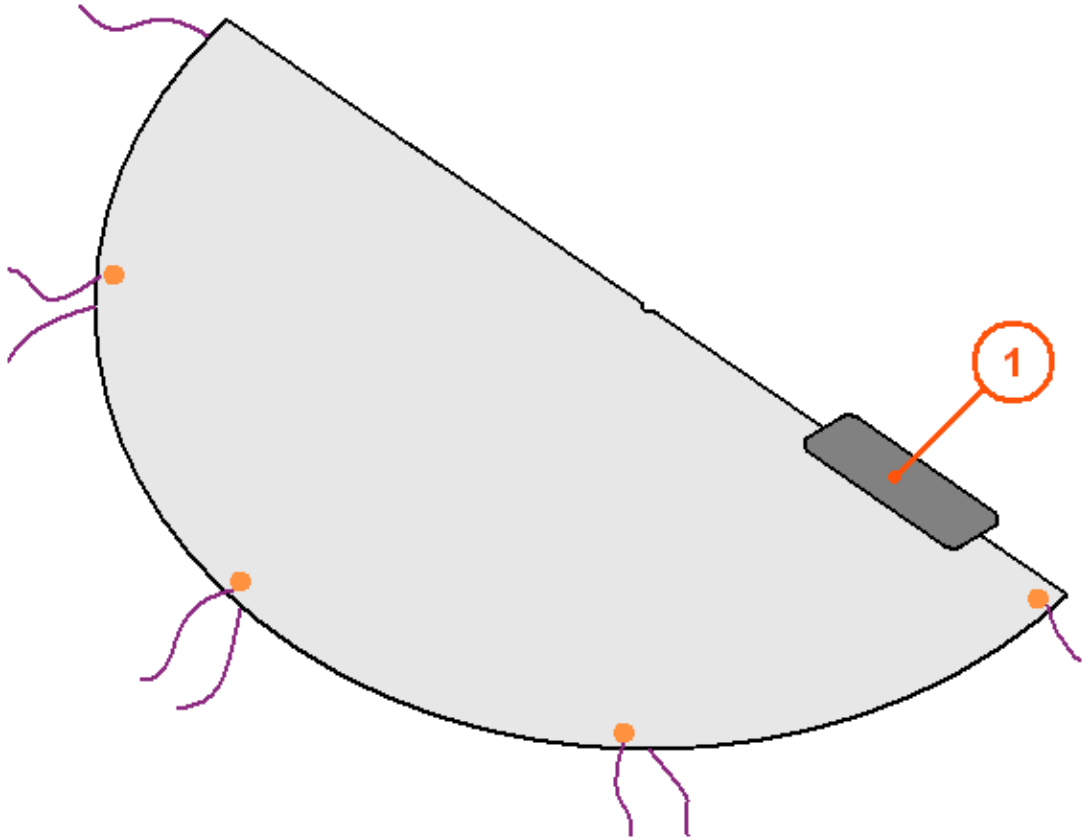

Draw. 5

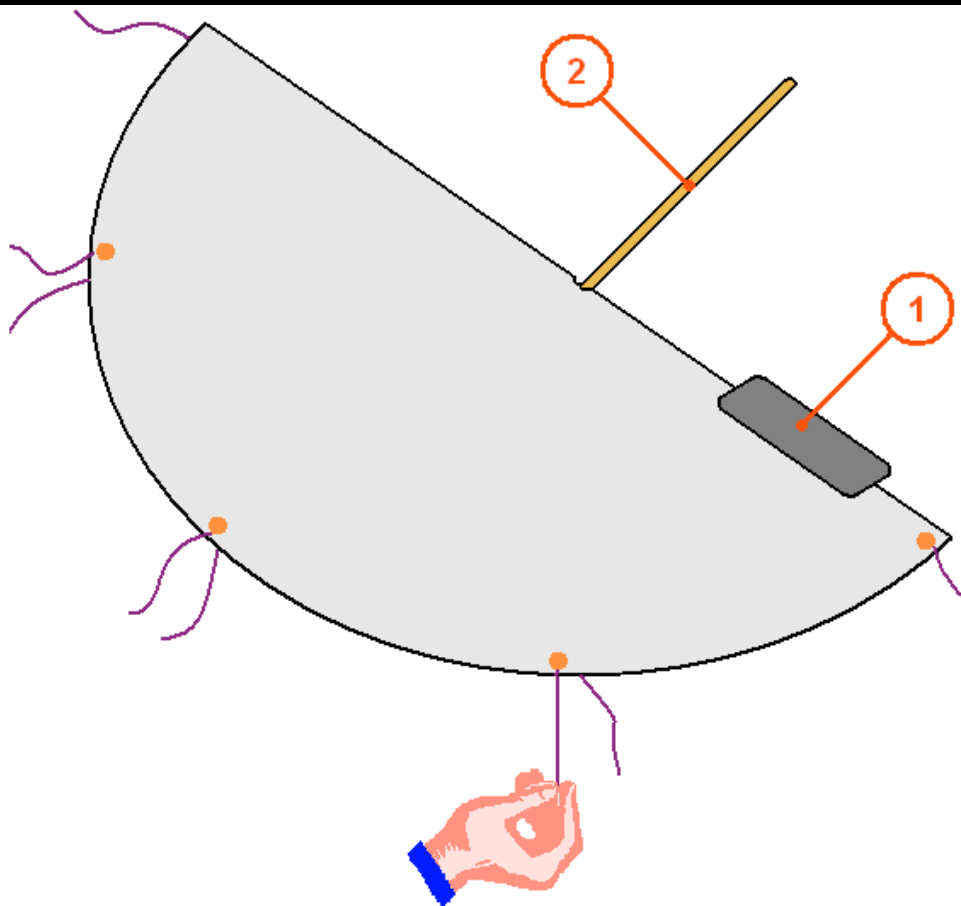

Draw. 6

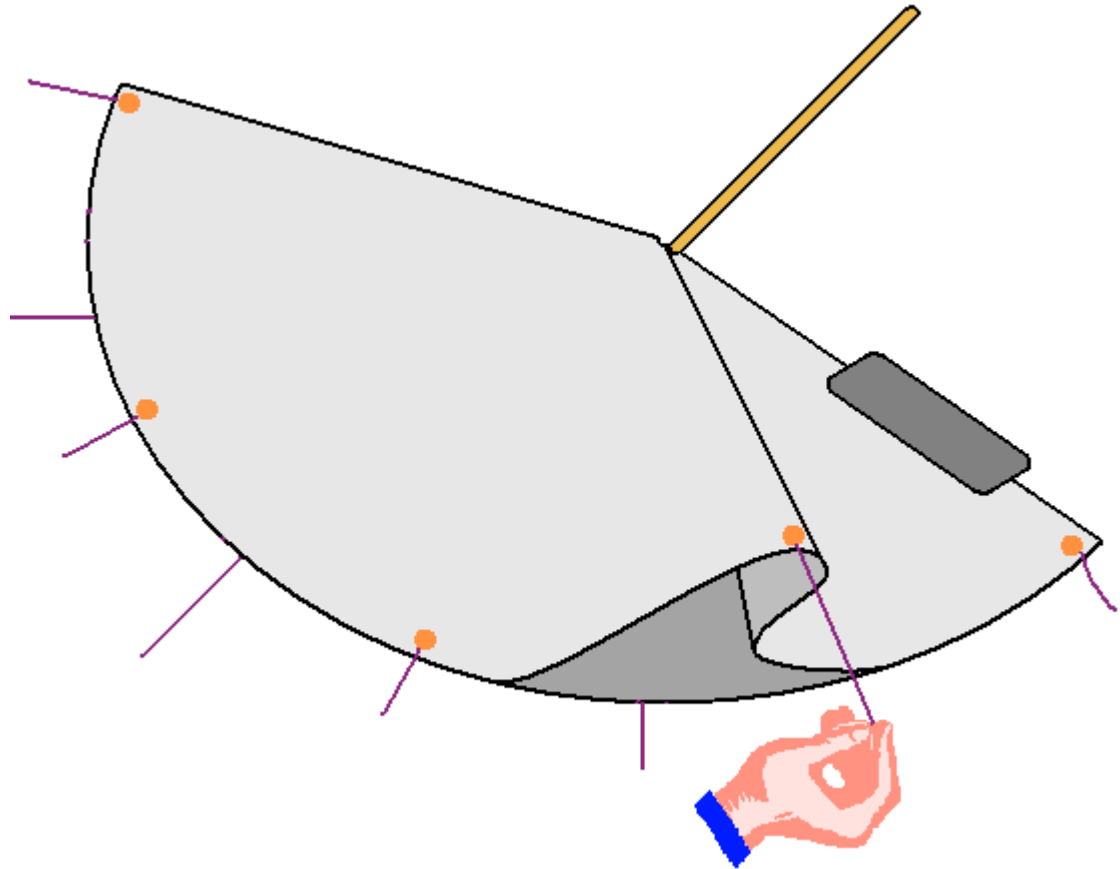

Draw. 7

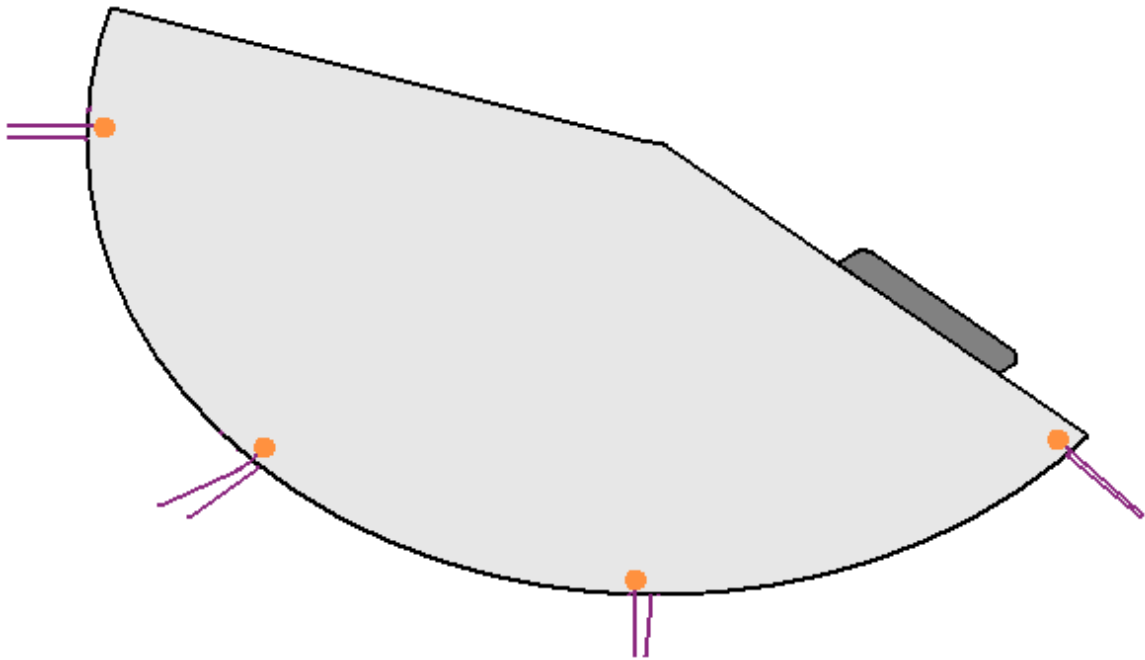

Draw. 8

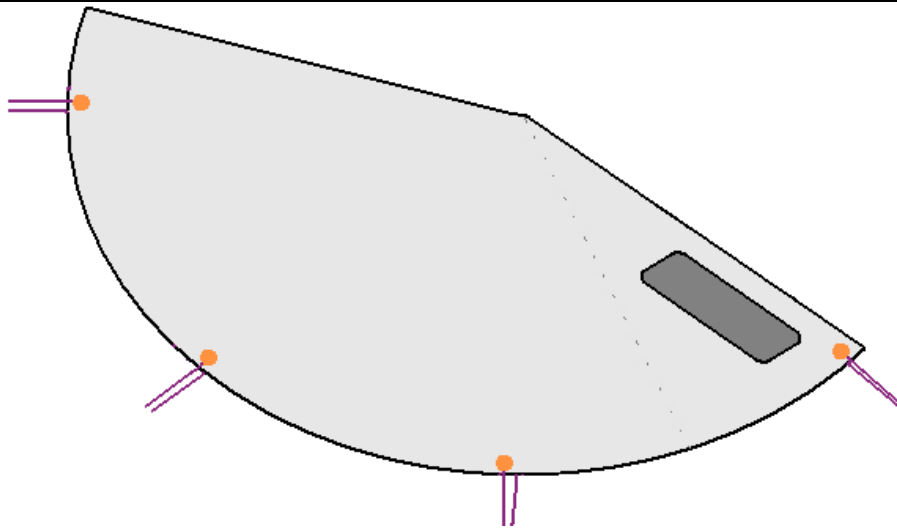

Draw. 9

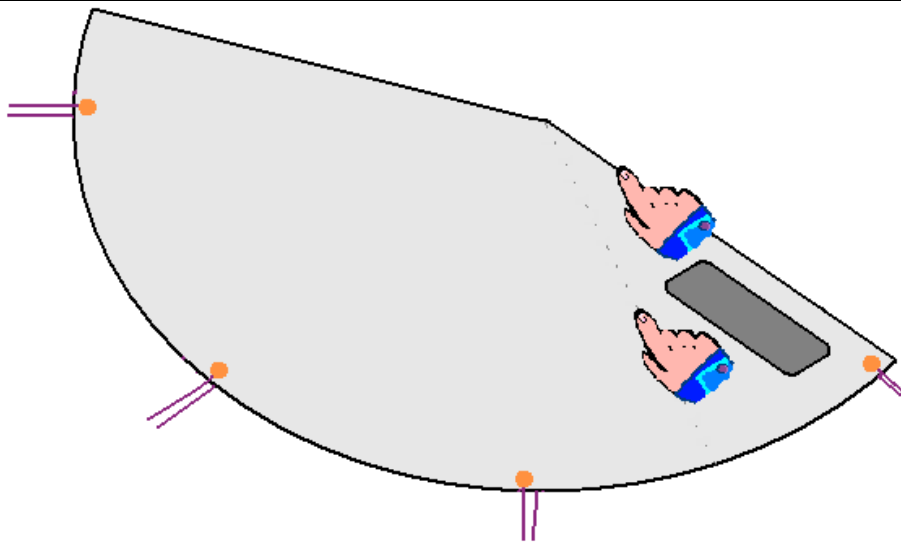

Draw. 10

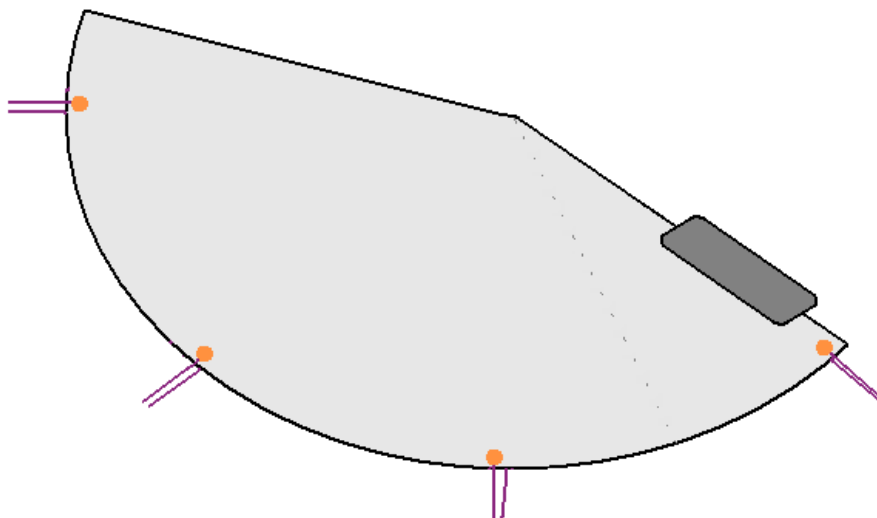

Draw. 11

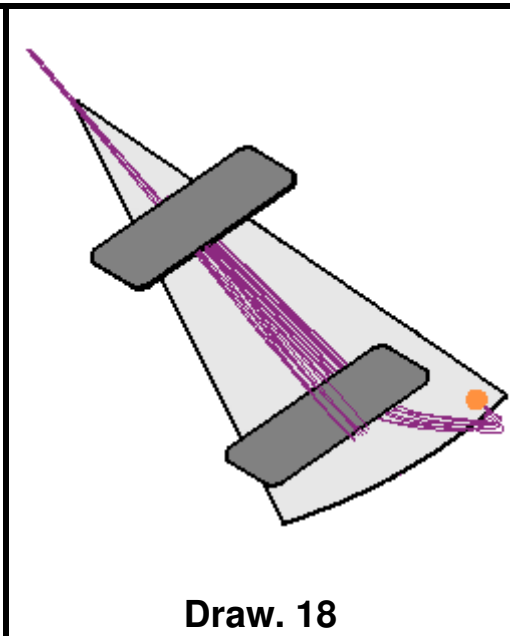
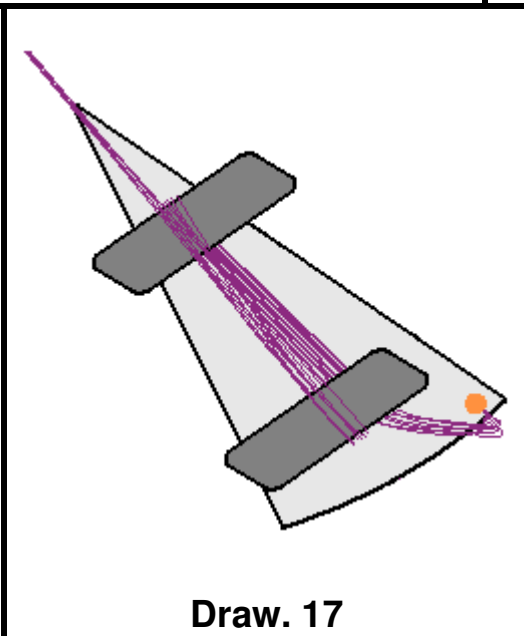
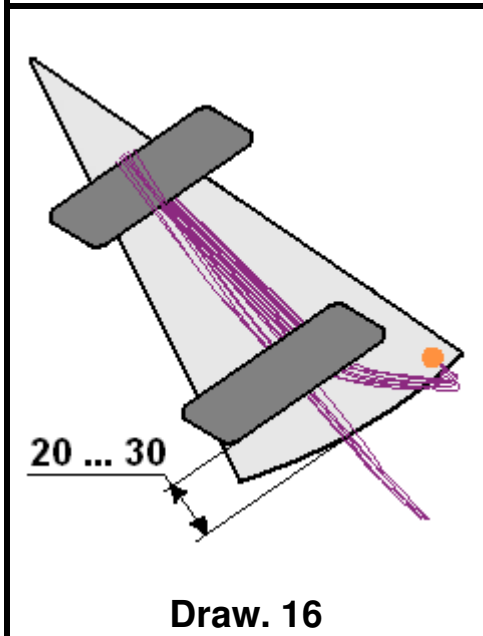
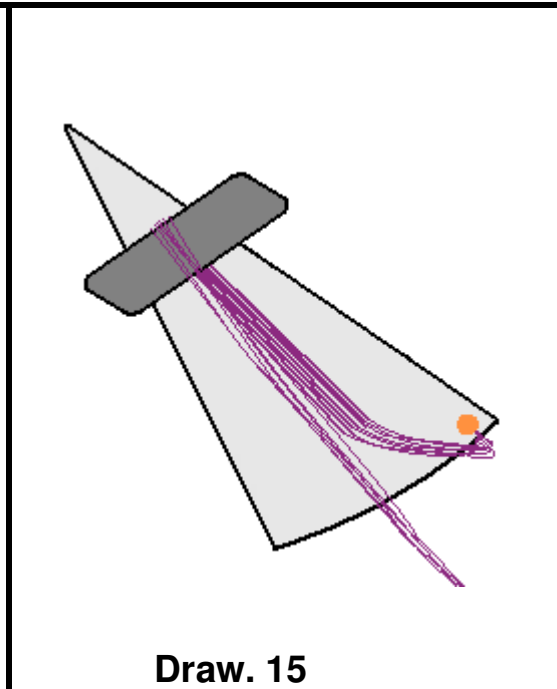
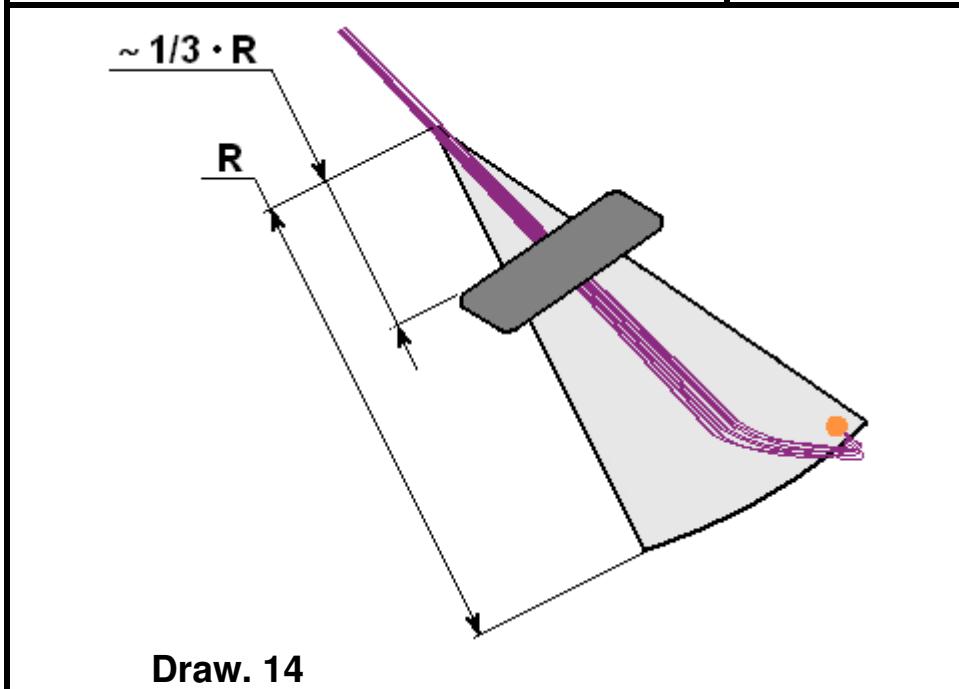
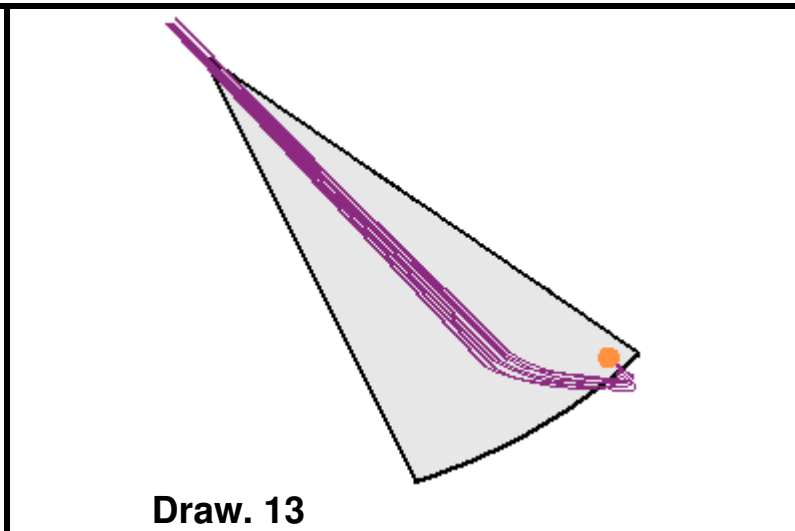
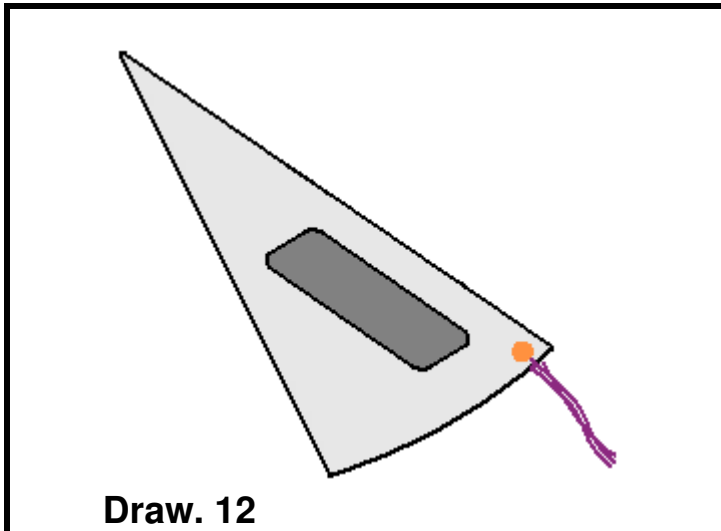

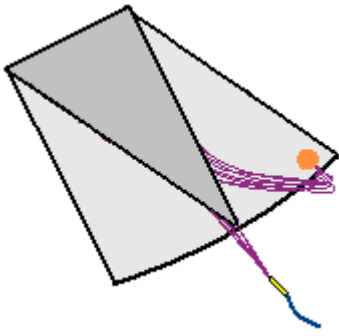

Draw. 19

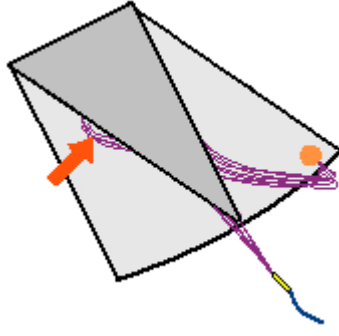

Draw. 20

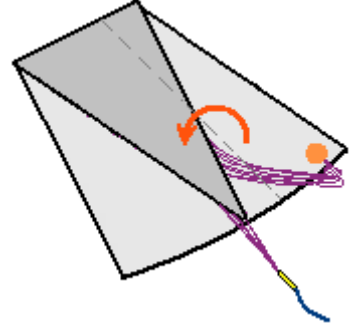

Draw. 21

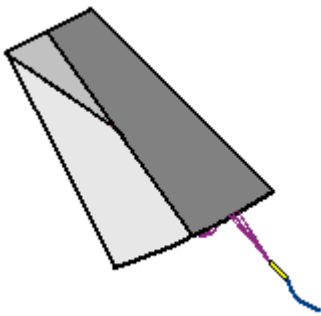

Draw. 22

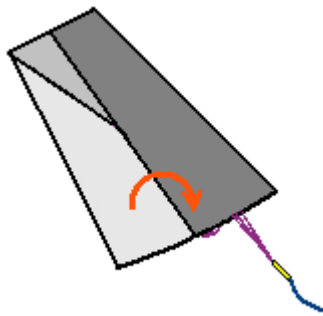

Draw. 23

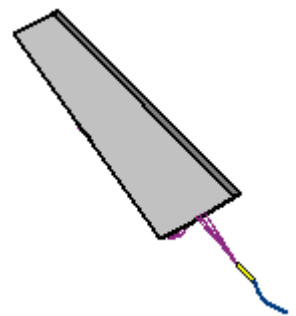

Draw. 24